



PEM735 Measuring case



Measuring and demonstration case



Bender GmbH & Co. KG

P. O. Box 1161 • 35301 Gruenberg • Germany
Londorfer Str. 65 • 35305 Gruenberg • Germany

Tel.: +49 6401 807-0

Fax: +49 6401 807-259

E-Mail: info@bender.de

www.bender.de

Photos: Bender archives

© Bender GmbH & Co. KG

All rights reserved.
Reprinting only with permission
of the publisher.
Subject to change!

Table of Contents

1. Function and safety	5
2. Content of the measuring case	6
3. Connecting the measuring case	7
3.1 Front plate	8
3.2 Wiring panel side	9
4. Current measurement	11
4.1 Application of the Rogowski coils	12
4.1.1 Settings on the case	13
4.1.2 Mounting Rogowski coils	14
4.1.3 Settings on the PEM735	14
4.2 Application of AUX transformers	15
4.2.1 Settings on the case	16
4.2.2 Mounting AUX transformers	16
4.2.3 Settings PEM735	16
4.3 Use of 3 Rogowski coils and 1 AUX transformer	17
4.3.1 Settings on the case	17
4.3.2 Mounting transformer	17
4.3.3 Settings PEM735	17
5. Voltage measurement	18
5.1 Overview material for voltage measurement	18
6. Digital inputs and relay outputs	19
6.1 Digital inputs DI1, DI2, DIC	19
6.2 Relay outputs RO1...2	19
7. Network	20

8. Technical data	21
9. Ordering information	23
INDEX	25

1. Function and safety

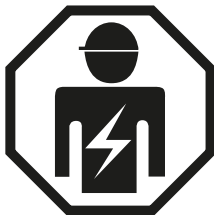

The PEM735 measuring and demonstration case is used for mobile measurements to analyse the voltage quality according to DIN EN 50160 (measurement according to IEC 61000-4-30 class A).

For the use of this measuring case, **specialist knowledge** is required.

It is essential to follow the existing safety regulations!

About this manual

In the schematic presentation, the elements belonging to the **Rogowski coils** are depicted in pink and all elements belonging to the **AUX transformers** are depicted in green.



DANGER

Risk of fatal injury from electric shock!

Incorrect wiring of the measuring voltage cables may cause a short-circuit of the installation, arcs and high short-circuit currents.

*The **secured side of the measuring voltage cable** (longer plug) **must be connected to the installation!***



DANGER

Risk of fatal injury from electric shock!

AUX transformers may not be operated as an open circuit on the secondary side!

Connected AUX transformers must be short-circuited with a jumper wire when not in use!

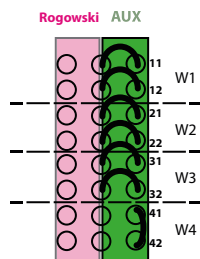

2. Content of the measuring case

- Universal measuring device PEM735 (IP address 192.168.0.10)
- Integrated WLAN router (IP address 192.168.0.254; admin/admin)
- 4 flexible Rogowski coils and transducers for current measurement 100...4000 A
- 1 current transformer clamp C112 (1000 A; 5 kHz)
- 1 current transformer clamp C148 (configurable 250/500/1000 A; 1 kHz)
- 5 cables with fuses for voltage measurement
- Safety test probes (crocodile clips, magnetic test probes, test probes for use with push-wire terminals)
- Trolley
- Case can be locked (padlock not included)



Abb. 2.1: Content of the measuring case

3. Connecting the measuring case

For your safety, consider the sequence of the work steps:

1. Configure measuring case mechanically (insert jumper wires for the transformers used, adjust transducers for Rogowski coils)
2. Install measuring current transformer
3. Commission measuring case
4. Configure PEM735
5. Install measuring voltage cables

The measuring case is operated with 230 V, 50 Hz. The connecting cable is included.

3.1 Front plate

The case contains the PEM735 connected to the front plate, a router, the transducers for the Rogowski coils and the jumper wires to configure the transformers being used.

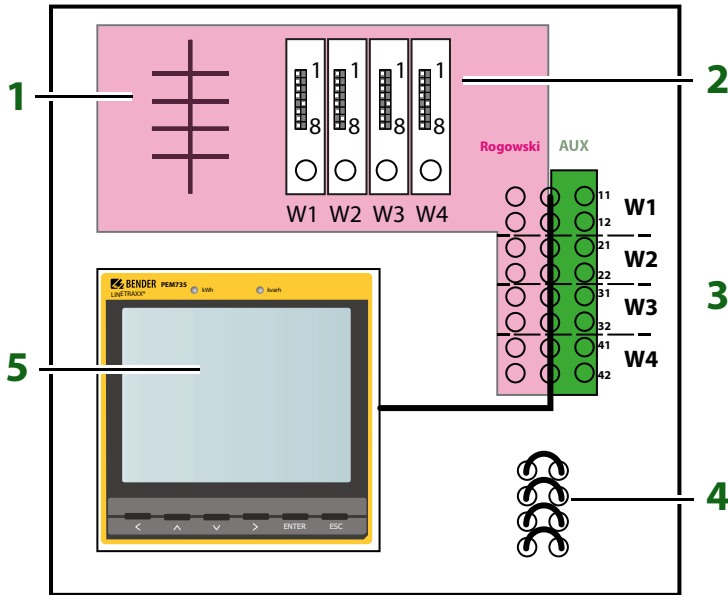

Fig. 3.1: Front plate

Legend front plate

No.	Description
1	Overview of the DIP switch settings for the transducers of the Rogowski coils
2	Transducers for the Rogowski coils
3	Jumper wire slots to configurate the measuring current transformers in use
4	Slots for replacement jumper wires
5	Universal measuring device PEM735

3.2 Wiring panel side

At the side of the measuring case you can find the

- Power supply of the measuring case
- Voltage transformer inputs
- Measuring current transformer inputs
- Network connection input
- Digital inputs
- Relay outputs

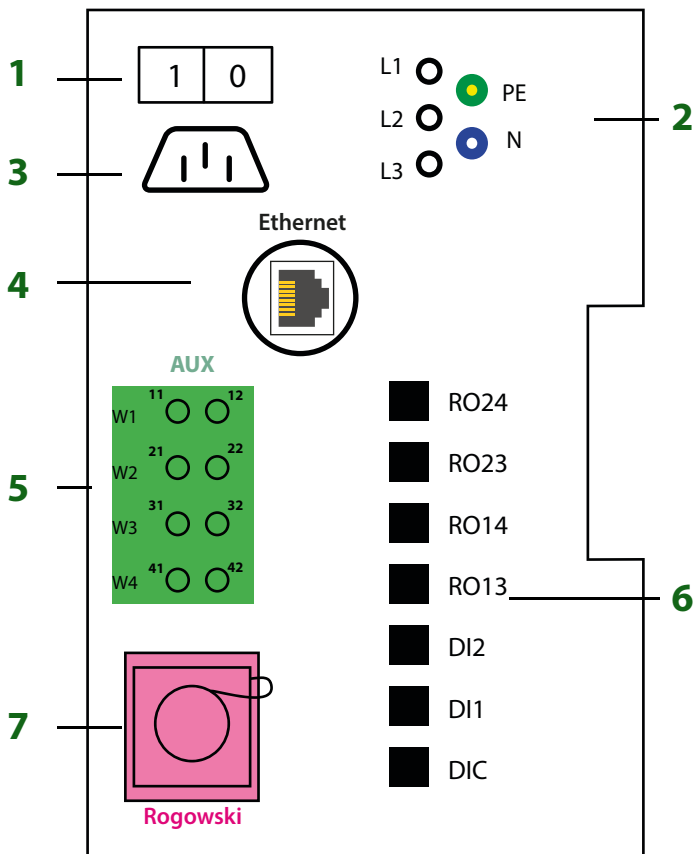

Fig. 3.2: Wiring panel side

Legend wiring panel side

No.	Description
1	On/off switch of the measuring case
2	Measuring voltage inputs
3	Power supply socket for measuring case
4	Ethernet connection socket
5	Measuring current transformer inputs
6	Digital inputs and relay outputs
7	Connection Rogowski coils

4. Current measurement

The universal measuring device PEM735 integrated in the measuring case is set to the "load meter arrow system".



*When installing the transformers, make sure that the **imprinted direction arrows point at the load**. Otherwise you will receive incorrect measurement values.*

The measuring case operates with Rogowski coils (on the left side of the image) and AUX transformers (on the right side of the image).



Fig. 4.1: Measuring current transformer included in the scope of delivery (left: 4 Rogowski coils, right: 2 current transformer clamps)

4.1 Application of the Rogowski coils

The 4 provided Rogowski coils are bundled together at one end with a plug that is connected to the socket on the side of the measuring case. For easier assignment of the measurement values, the Rogowski coils are labelled (5A1...4).

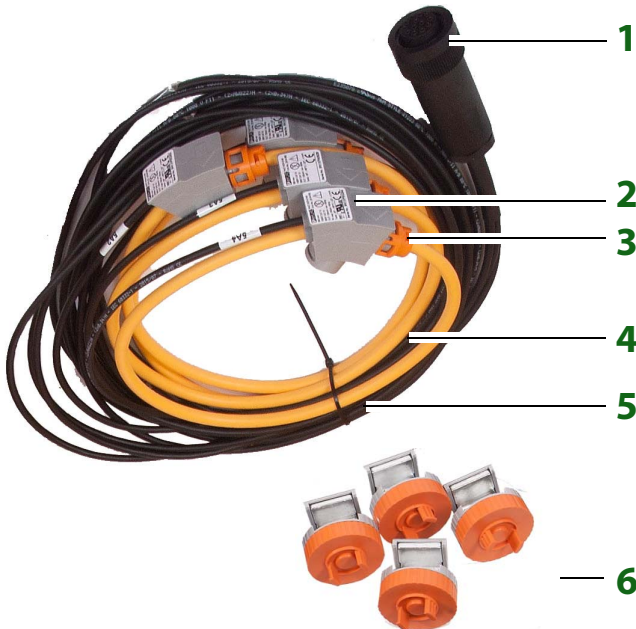

Fig. 4.2: Rogowski coil

Legend Rogowski coil

No.	Description
1	Plug of the 4 Rogowski coils
2	Coil enclosure
3	Bayonet connection
4	Measuring coil (orange)
5	Signal cable (black)
6	Mounting aid for busbar measurement

4.1.1 Settings on the case

1. Disconnect measuring case.
2. Set the transducers W1...4 for the Rogowski coils to the expected measuring range using the DIP switches.

i

*Changes to the DIP switches can only be carried out when the power supply is **disconnected!***

DIP switch

Use the DIP switches to set the conversion ratio of the Rogowski coils at the transducers.

DIP switch for transducers (conversion table for primary currents Rogowski)	
1 = 4000 A	<i>In the example, the range "630 A" is set.</i> 
2 = 2000 A	
3 = 1500 A	
4 = 1000 A	
5 = 630 A	
6 = 400 A	
7 = 250 A	
8 = 100 A	

Table 4.1: Table DIP switches for transducers

For "**Compensation**", the length of the used Rogowski coil is indicated in mm. The supplied Rogowski coils must be set to 600.

3. All 8 jumper wires must be inserted in **position "Rogowski"**.

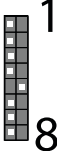
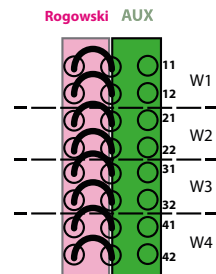

4.1.2 Mounting Rogowski coils

Power supply line

1. Open the Rogowski coil by turning the orange bayonet connection anti-clockwise and pulling the measuring coil out of the coil enclosure.
2. Put the measuring coil around the line to be measured.
3. Position the measuring coil in the coil enclosure and close the orange bayonet connection with an audible click.
4. Place the coil enclosure on the power supply line with the flange at right angles.
5. Lead a cable tie around the power supply line and pull it through the gaps of the flange.

Busbars

For easier measurement of the busbars, 4 busbar mounting supports are included.

1. Open the orange knurled screw of the busbar mounting support anti-clockwise so that you can place the busbar mounting support on the top edge of the busbar.
2. Make sure it is correctly placed.
3. Fix the knurled screw clockwise hand-tight.
4. Open the Rogowski coil and place the measuring coil around the busbar.
5. Push the flange of the coil enclosure as far as possible on the two guide ribs of the knurled wheel.
6. Insert the measuring coil into the coil enclosure and close the orange bayonet connection with an audible click. The ideal position and orientation of the Rogowski coil is when the current-carrying conductor is placed in the centre of the coil.
7. Make sure that the measuring coil and the signal cable do not touch any busbar. If necessary, you can adjust the enclosure position clockwise in 15° steps.

Disassemble in reverse order.

4.1.3 Settings on the PEM735

1. Commissioning measuring case with mains plug.
2. Set primary current to measuring range (**Settings / Basic / CT Primary**)
3. Set secondary current to 1 A (**Settings / Basic / CT Secondary**)

4.2 Application of AUX transformers



Up to 4 AUX transformers can be connected to the measuring case.



DANGER

Risk of fatal injury from electric shock!

AUX transformers may not be operated as an open circuit on the secondary side!

Connected AUX transformers must be short-circuited with a jumper wire when not in use!

Example:

- Application of 3 AUX transformers.
- AUX4 not in use, therefore short-circuited

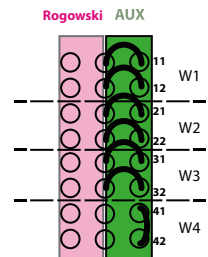

When using your own measuring current transformers, be aware that the secondary current may have a maximum of 5 A!

4.2.1 Settings on the case

The jumper wires of the transformers in use must be plugged into **position "AUX"**.

4.2.2 Mounting AUX transformers

Connect the measuring cables to the measuring current transformer and the case (inputs AUX W1...4 on the outside).

The measuring case includes 2 current transformer clamps.

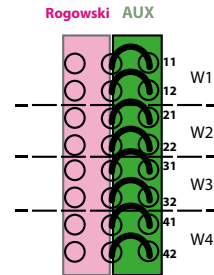

	C112	C148
Measuring range	10 mA... 1000 A	250 A; 500 A; 1000 A
Secondary current	max. 1 A	max. 5 A
Frequency range	max. 5 kHz	max. 1 kHz

red measuring cable socket X1

black measuring cable socket X2

4.2.3 Settings PEM735

C112

Primary current 1000 A (**Settings / Basic / CT Primary**)

Secondary current 1 A (**Settings / Basic / CT Secondary**)

C148

Primary current as measuring range (**Settings / Basic / CT Primary**)

Secondary current 5 A (**Settings / Basic / CT Secondary**)

4.3 Use of 3 Rogowski coils and 1 AUX transformer



A mixed operation of

- Rogowski coils for the three phases
- AUX transformers (e.g. current transformer clamps) for the neutral conductor

is possible.

4.3.1 Settings on the case

1. **Deenergise** measuring case. Set the **DIP switch** of the transducers to the correct measuring range.
2. The six jumper wires **W1...W3** must be plugged into position "**Rogowski**".
3. The two jumper wires **W4** must be plugged into position "**AUX**".

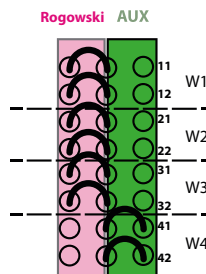

4.3.2 Mounting transformer

W1...3: Install the three Rogowski coils 5A1...3 (refer to chapter 4.1.2).

W4: Install the AUX transformer (refer to chapter 4.2.2).

4.3.3 Settings PEM735

Primary current W1...3

as measuring range

(Settings / Basic / CT Primary)

Secondary current W1...3

1 A **(Settings / Basic / CT Secondary)**

Primary current neutral conductor W4

fits AUX transformer

(Settings / Basic / I4 Primary)

Secondary current neutral conductor W4

fits AUX transformer

(Settings / Basic / I4 Secondary)

5. Voltage measurement



DANGER

Risk of fatal injury from electric shock!

First connect the laboratory plugs to the case.

Only after this step the measuring voltage cables may be connected to the system.



DANGER

Risk of fatal injury from electric shock!

Incorrect wiring of the measuring voltage cables may cause a short-circuit of the installation, arcs and high short-circuit currents.

Never use measuring cables without integrated fuse for voltage coupling!

The **side of the measuring voltage cable with the fuse (longer plug) must be connected to the installation.**

5.1 Overview material for voltage measurement



Fig. 5.1: Overview material for voltage measurement

From left to right: secured measuring voltage cables, crocodile clips, safety crocodile clips, magnetic test probes

Connect the measuring voltage cable to the corresponding socket L1...3/N/PE at the side of the case.

To connect the secured side of the measuring voltage cable you have the following options:

- Crocodile clips (PE always, for other cables optional)
- Safety crocodile clips for use with push-wire terminals
- Magnetic test probes to enable the screws to make contact with the circuit breaker

6. Digital inputs and relay outputs

The digital inputs and the relay outputs are located at the outside of the measuring case.

6.1 Digital inputs DI1, DI2, DIC

The measuring case offers 2 digital inputs. The inputs are supplied by a galvanically isolated DC 24 V voltage. An external circuit providing at least a current of $I_{min} > 2.4 \text{ mA}$ is required for triggering the inputs.

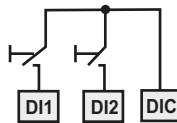

Fig. 6.1: Digital inputs

6.2 Relay outputs RO1...2

The measuring case features two relay outputs. .

	Rated operational voltage	AC 230 V	DC 24 V	AC 110 V	DC 12 V
	Rated operational current	5 A	5 A	6 A	5 A

Table 6.1: Relay outputs

7. Network

Thanks to the integrated router you can access the measurement results and settings of the PEM735 via WLAN. Additional notes regarding the use of the PEM735, the Modbus register overview and the web application can be found in the manual and annexes of the PEM735.

Ethernet address

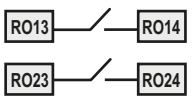
PEM735: IP 192.168.0.10

WLAN: IP 192.168.0.254 (admin/admin)

For seamless communication it is important that the PEM735 and the router are in the same network.

Default setting:

- Access point
- DHCP activated

Connecting a device to the WLAN (SSID=PEM735)

Integrating the WLAN into existing networks: refer to WLAN router documentation.

8. Technical data

Insulation coordination

Measuring circuit

Rated insulation voltage.....	600 V
Overvoltage category.....	III
Pollution degree.....	2

Supply circuit

Rated insulation voltage.....	300 V
Overvoltage category.....	II
Pollution degree.....	2

Supply voltage

Rated supply voltage U_S	110 . . . 240 V
Frequency range of U_S	47 . . . 63 Hz

Measuring circuit

Measuring voltage inputs

UL1-N,L2-N,L3-N	400 V
UL1-L2,L2-L3,L3-L1	690 V
Measuring range	10 . . . 120 % U_n
Rated frequency	45 . . . 65 Hz
Internal resistance (L-N)	> 6 M Ω

Measuring current inputs

External measuring current transformers	should at least comply with accuracy 0.2 S
Burden	n.A., internal current transformers
Measuring range	0.1 . . . 120 % I_n
Measuring current transformer conversion ratio, secondary	1 . . . 5 A
Measuring current transformer conversion ratio, primary	1 . . . 30000 A

Accuracies (mv = of measured value/fs = of full scale value)

Phase voltage $U_{L1-N}, U_{L2-N}, U_{L3-N}$	± 0.1 % mv
Current	± 0.1 % mv + 0.05 % fs
Frequency	± 0.005 Hz
Phasing	$\pm 1^\circ$
Measurement of the active energy	acc. to DIN EN 62053-22 (VDE 0418 Part 3-22)
Measurement of the voltage r.m.s. values.....
.....	acc. to DIN EN 61557-12 (VDE 0413-12), chapter 4.7.6

Measurement of the phase current r.m.s. values acc. to DIN EN 61557-12 (VDE 0413-12), chapter 4.7.5
Frequency measurement acc. to DIN EN 61557-12 (VDE 0413-12), chapter 4.7.4
Measurement of the harmonics acc. to DIN EN 61000-4-7 class A	

Interface

Interface/protocol	RJ-45, Modbus TCP
--------------------------	-------------------

Switching elements

Outputs (RO)	2 x N/O contacts
Operating principle	N/O operation
Rated operational voltage	AC 230 V DC 24 V AC 110 V DC 12 V
Rated operational current	5 A 5 A 6 A 5 A
Minimum contact rating	1 mA at AC/DC \geq 10 V
Inputs	2 electrically separated digital inputs
I_{\min}	2.4 mA
U_{DI}	DC 24 V

Environment/EMC

Operating temperature.....	0 ... + 40 °C
Classification of climatic conditions	acc. to DIN EN 60721
Height	up to 4000 m

Other

Degree of protection	IP20
Dimensions	approx. 556 x 416 x 295 mm
Weight	\leq 16 kg

9. Ordering information

Type	Art. no.
PEM735 Measuring case	B 9830 0014

INDEX

A

AUX transformers 15

B

Bayonet connection 12

C

Coil enclosure 12

Compensation 13

Connecting the measuring case 7

Current measurement 11

D

Digital inputs 9, 19

DIP switch 13

Direction arrows 11

F

Front plate 8

M

Measuring coil 12

Measuring current transformer inputs 9

Mounting aid 12

Mounting Rogowski coils busbars 14

Mounting Rogowski coils power supply line 14

N

Network 20

Network connection 9

P

Power supply 9

R

Relay outputs 9, 19

Rogowski coil 12

S

Signal cable 12

V

Voltage measurement 18

Voltage transformer inputs 9

W

Wiring panel side 9



Bender GmbH & Co. KG

P. O. Box 1161 • 35301 Gruenberg • Germany
Londorfer Str. 65 • 35305 Gruenberg • Germany

Tel.: +49 6401 807-0

Fax: +49 6401 807-259

E-Mail: info@bender.de

www.bender.de

