

Insulation monitoring device for  
IT DC systems 350 ... 800 V

## IR5000

## Operating Manual

**Insulation monitoring device IR5000 - Operating manual**  
**TGH 1269E    Edition 04.2002**

Edited by  
Dipl.-Ing. W. BENDER GmbH+CoKG

This manual may not be copied, in whole  
or part, without written consent of BENDER.  
All rights reserved.  
Right to modifications reserved.



Dipl.-Ing. W. Bender  
GmbH+CoKG  
Londorfer Str. 65  
D-35305 Grünberg  
Postfach 1161  
D-35301 Grünberg  
Tel. 06401/807-0  
Fax 06401/807-259  
E-Mail [info@bender-de.com](mailto:info@bender-de.com)

# Contents

---

1 General .....	4
About the IR5000 .....	4
IT System .....	4
Underlying standards .....	4
The concept of IR5000 .....	5
Coupling device AG5000 .....	5
2 Safety information .....	6
Intended use .....	6
Personnel .....	6
Copyright .....	6
Warranty and liability .....	7
Explanation of symbols and warnings .....	7
Hazards when handling the system .....	7
Inspection, transport and storage .....	8
Warranty statement .....	8
3 Principle of operation .....	9
Symmetrical and asymmetrical insulation faults .....	10
4 Product description .....	11
Mechanical design .....	11
Dimension diagrams .....	12
Wiring diagram .....	14
Legend to wiring diagram .....	15
Terminal strips .....	16
5 Setting and operation .....	17
Function keys .....	17
Welcome screen .....	17
Main screen .....	17
Menus .....	18
The individual menus .....	19
Setting the response values .....	19
Time response .....	19
Indication of the time response .....	21
Operating principle of the alarm relays .....	21
N/O or N/C operation .....	22
Setting the threshold of the voltage .....	22
Setting the serial interface .....	23
Adjusting digital input 1 .....	23
Temperature display .....	24
Setting date and time .....	24
Software version .....	25
Factory settings .....	25
6 Wiring and commissioning .....	26
Error messages .....	29
System errors, CRITICAL ERRORS .....	30
Indication of asymmetrical faults .....	31
Data output .....	32
7 Technical Data .....	33
Analog output IR5000 .....	35
8 ISODATA for IR5000 .....	35
Hardware pre-conditions .....	35
Program start .....	35
File size .....	36
The main screen .....	36
The submenus .....	36

# 1 General

---

## About the IR5000

With the insulation monitoring device IR5000, BENDER offers a special equipment for continuous monitoring of the insulation resistance of IT DC systems to earth. The device is intended to indicate when the value falls below a preset response value.

The IR5000 is suitable for IT DC systems involving:

- systems with low insulation resistance and high nominal voltages
- systems with water-cooled components
- heating systems with ionizing air
- smelting plants
- extended systems

Special features of the IR5000 are:

- voltage range of the system to be monitored:  
DC 350 ... 800 V
- 3-voltmeter method for fast detection of symmetrical and asymmetrical insulation faults
- wide response range:  $5\Omega$  ...  $100\text{ k}\Omega$
- integrated voltage monitoring
- two serial interfaces: RS232 and RS485
- linear analog output 0...20 mA
- three different alarm relays for earth fault at L+, earth fault at L- and system faults
- large LC display
- control via microcontroller
- real-time clock
- menu-driven operating and setting
- robust enclosure for surface mounting

## IT System

If increased availability of power supply is concerned, the IT system, i.e. the unearthed system, is the right choice. In contrast to the earthed system, the first insulation fault does not lead to a disconnection. Combined with a well-chosen insulation monitoring device, insulation faults and deteriorations are recognized early, possibly when developing. Hence, increased availability of power supply in an IT system stands and falls with the well-chosen insulation monitoring device.

Maintaining a good insulation condition is decisive for reliable power supply. Therefore the relevant standards demand that the first fault is to be cleared as soon as possible.

## Underlying standards

### IEC 60364-4-41, Punkt 413.1.5.4 (Note):

It is recommended that the first fault should be eliminated with the shortest practical delay.

The A-ISOMETER<sup>®</sup> IR5000 complies with the requirements of IEC 61557-8. The internal resistance has been adapted to the special applications for systems with low insulation resistance values.

The standard deals with constructional and measuring parameters as well as the test procedures, and the safety aspects of the insulation monitoring devices in IT systems, including the use in IT AC systems, IT DC systems and IT DC systems with galvanically connected DC circuits.

# General

---

IR5000 works according to a passive 3-voltmeter method. Different voltages are measured within the system to be monitored. Comparative measurements of the internal resistor network are carried out in order to determine the correct insulation resistance of the system.

## **The concept of IR5000**

For calculation of the insulation resistance, the measured analog voltages are digitized by a 22-bit AD converter which is connected to the microcontroller via a serial bus.

The detection, processing, analysis and output of the measured values are controlled by a microcontroller which allows the setting of different parameters. The measured values can be transmitted to peripheral devices, e.g. computers or PLC via serial interfaces.

The device parameter settings are stored in a non-volatile EEPROM. The values of the insulation resistance and the time when the measurements are carried out are indicated by the internal real-time clock.

The measuring circuit is isolated from the output circuits (relays, interfaces). That provides adequate safety of the IR5000 and the connected peripheral devices.

IR5000 can be used as an independent device or in combination with the coupling device AG5000. If response values below 1000  $\Omega$  are to be set, the use of a coupling device AG5000 will be necessary. IR5000 recognizes automatically if a coupling device has been connected.

## **Coupling device AG5000**

## 2 Safety information

---

### Intended use

**IR5000 is intended exclusively for measuring and evaluating the insulation resistance in IT DC systems of 350 V to 800 V.**

Any other use, or any use which goes beyond the foregoing, is deemed to be use other than for the intended purpose. The BENDER companies shall not be liable for any losses or damage arising therefrom.

The basic requisite for handling the IR5000 in accordance with safety requirements, and for it to operate without faults, is a knowledge of the fundamental safety information and the safety regulations.

This manual contains important information needed in order to operate the IR5000 in accordance with safety requirements. This manual, and in particular the safety information, must be noted by all persons who work with the IR5000.

In addition, it is essential to comply with the rules and regulations on accident prevention which are valid for the place of use.

### Personnel

Only appropriately qualified personnel may work on the IR5000. "Qualified" means that such personnel are familiar with the installation, commissioning and operation of the product and that they have undergone training or instruction which is appropriate to the activity.

The personnel must have read and understood the safety chapter and the warning information in this operating manual.

### Copyright

The copyright to this operating manual shall remain with the BENDER Companies. The operating manual is solely intended for the operator and his personnel. It contains regulations and information which must not be reproduced, disseminated or otherwise divulged, either in whole or in part. Contraventions may entail criminal prosecution.

### Warranty and liability

As a basic principle, our "General Conditions of Sale and Delivery" shall apply. At the latest, these shall be available to the operator when the contract is concluded. Warranty and liability claims in cases of damage to persons and property shall be excluded if they are attributable to one or more of the following causes:

- use of the IR5000 other than for the intended purpose
- incorrect assembly or installation, commissioning, operation and maintenance of the IR5000
- failure to comply with the information in the operating instructions regarding transport, storage, assembly or installation, commissioning, operation and maintenance of the IR5000
- unauthorized structural modifications to the IR5000
- failure to comply with the technical data
- improperly executed repairs, and the use of spare parts or accessories which are not recommended by the manufacturer
- cases of disaster and force majeure  
normal control, e.g. acts of God

# Safety information

---

The following designations and signs are used for hazards and warnings in Bender documentation.

This symbol means an immediate threat of danger to the life and health of human beings.  
Failure to comply with these warnings means that death, serious physical injury or substantial damage to property **will** ensue if the relevant precautions are not taken.



This symbol means a possible threat of danger to the life and health of human beings.  
Failure to comply with these warnings means that death, serious physical injury or substantial damage to property **may** ensue if the relevant precautions are not taken.



This symbol means a possible dangerous situation.  
Failure to comply with these warnings means that slight physical injury or damage to property may ensue if the relevant precautions are not taken.



This symbol gives important information about the correct handling of the IR5000.  
Failure to comply with this information can result in faults on the IR5000 or in its environment.



Where you see this symbol, you will find application tips and other particularly useful information.  
This information will help you to make optimal use of the IR5000.



The IR5000 is constructed according to the state-of-the-art and the recognized safety engineering rules. Nevertheless, when it is being used, hazards may occur to the life and limb of the user or of third parties, or there may be adverse effects on the IR5000 or on other valuable property. The IR5000 must only be used:

- for the purpose for which it is intended
- when it is in perfect technical condition as far as safety is concerned

Impermissible modifications and the use of spare parts and additional devices which are not sold or recommended by the manufacturer of the devices may cause fire, electric shocks and injury.

Make sure that the operating voltage is correct!  
Unauthorized persons must not have access to or contact with the IR5000.  
Warning signs must always be easily legible. Damaged or illegible signs must be replaced immediately.

Check the dispatch packaging and the equipment packaging for damage, and compare the contents of the package with the delivery documents. In the event of damage during transport, please notify BENDER immediately.  
The IR5000 must only be stored in rooms where it is protected against dust and moisture, and spraying or dripping water, and where the indicated storage temperatures are maintained.

## Explanations of symbols and warnings

## Hazards when handling the system

## Inspection, transport and storage

# Safety information

---

## Warranty statement

In respect of the IR5000, BENDER provides a warranty of fault-free execution and perfect material quality under normal operation and maintenance conditions, for a period of 12 months from the date of delivery. This warranty does not extend to all accessories and consumable components.

For warranty the device must be returned, prepaid, to the nearest authorized Bender service representative.

The warranty shall only be valid for the first purchaser, and shall not extend to products or individual parts thereof which have not been correctly used, or which have undergone modifications. Any warranty shall lapse if the IR5000 is used other than for the intended purpose.

The warranty obligation is limited to the repair or the exchange of a product which has been sent to BENDER within the warranty period. The qualifying conditions are that BENDER shall recognize the product as being faulty, and that the fault cannot be attributed to improper handling or modification of the device, nor to abnormal operating conditions.

Any warranty obligation shall lapse if repairs are undertaken on the IR5000 by persons who are not authorized by BENDER.

The foregoing warranty provisions are valid exclusively, and instead of all other contractual or legal warranty obligations, including (but not restricted to) the legal warranty of marketability, suitability for use and expediency for a specified use.

BENDER shall not assume any liability for direct or indirect concomitant or subsequent damage, regardless of whether these are attributable to legal, illegal or other actions.

This statement of warranty shall only be valid in conjunction with the delivery note from BENDER company.



### 3 Principle of operation

IR5000 uses the measuring principle "3-Voltmeter-Method". Asymmetrical as well as symmetrical insulation faults in IT DC systems can be detected according to this measuring principle. In combination with the microcontroller a fast, safe and exact measurement and evaluation can be realized.

In some respect, the measuring time is dependent on the system leakage capacitances  $C_{E+}$  and  $C_{E-}$  (illustrated below). The capacitances are always recharged when the coupling switches are closed resp. opened.

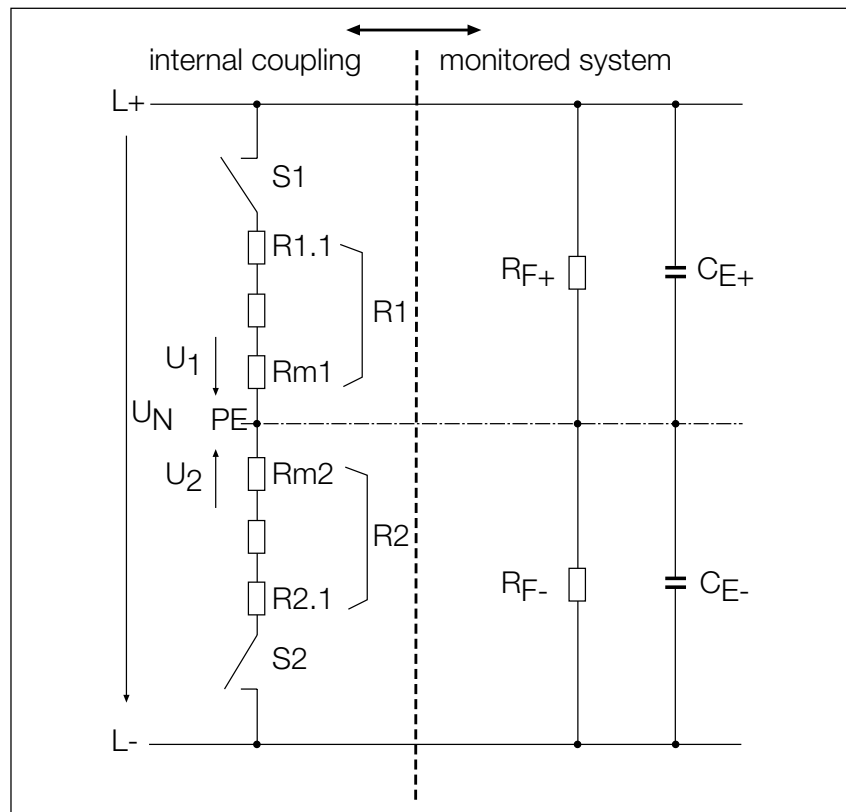

The time delay prevents false trippings during recharging:

- S1 closed, S2 opened                      measuring of the voltage  $U_1$  at  $R_{m1}$
- S1 opened, S2 closed                    measuring of the voltage  $U_2$  at  $R_{m2}$
- S1 and S2 closed                         measuring of the voltage  $U_N$

$$U_N = (U_1 + U_2) \times \frac{R_1 + R_2}{R_{m1} + R_{m2}}$$

# Principle of operation

---

The insulation resistances  $R_{F+}$  and  $R_{F-}$  can be calculated according to the following equations:

- for symmetrical coupling, i.e.  $R_1=R_2$  and  $R_{m1}=R_{m2}$

$$R_{E+} = \frac{(U_N \times R_{m1} - (U_1+U_2) \times R_2)}{U_2}$$

$$R_{E-} = \frac{(U_N \times R_{m2} - (U_1+U_2) \times R_1)}{U_1}$$

- for asymmetrical coupling, i.e. relation  $AK^+ / AK^- = 2:1$

$$R_{E+} = \frac{(U_N \times R_{m1} \times (U_N \times R_{m2} - R_2 \times (U_1 + U_2)))}{(U_2 \times (U_N \times R_{m1} - U_1 \times R_2))}$$

$$R_{E-} = \frac{(U_N \times R_{m1} \times (U_N \times R_{m2} - R_2 \times (U_1 + U_2)))}{(U_1 \times (U_N \times R_{m2} - U_2 \times R_2))}$$

Condition:  $R_1 = 2 \times R_2$   
 $R_{m1} = 2 \times R_{m2}$

These calculations of the insulation resistances are done by the integrated microcontroller. The results are indicated on the display.

## Symmetrical and asymmetrical insulation faults

The measuring values are determined by the device with a passive measuring principle. This entails some specialities regarding the measured insulation values.

If the relation between the single insulation values  $R_{F+}$  and  $R_{F-}$  is high (asymmetrical faults) the accuracy of the higher value is less than the accuracy of the lower value, because the measuring voltage drop for an insulation fault is gathered at the opposite side of the coupling network. That means that the main measuring voltage for the higher value decreases with the dropping of the lower insulation value. In the reverse case the measuring voltage of the lower value increases with the dropping of this value. Because of this, the lower value is measured with the highest accuracy.

In practice, this effect may entail a little change of the higher value in display when the lower value increases or decreases.  
The accuracy of both values is identical if the insulation values are symmetrical.

## 4 Product description

IR5000 is mounted in a 19"-inch plastic casing with a lockable transparent cover. The casing is equipped with two separate terminal boxes. The upper terminal box contains terminals for the coupling to the system to be monitored as well as to the optional coupling device AG5000. The lower terminal box contains terminals for PE coupling, supply voltage, contacts of the alarm relay, serial interfaces, temperature sensor input, digital inputs, and analog output.

### Mechanical design

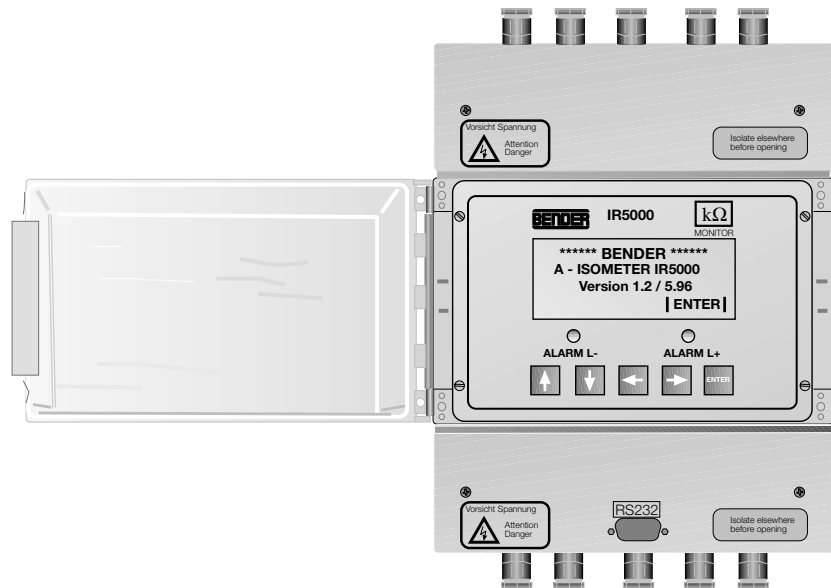

# Product description

## Dimension diagrams

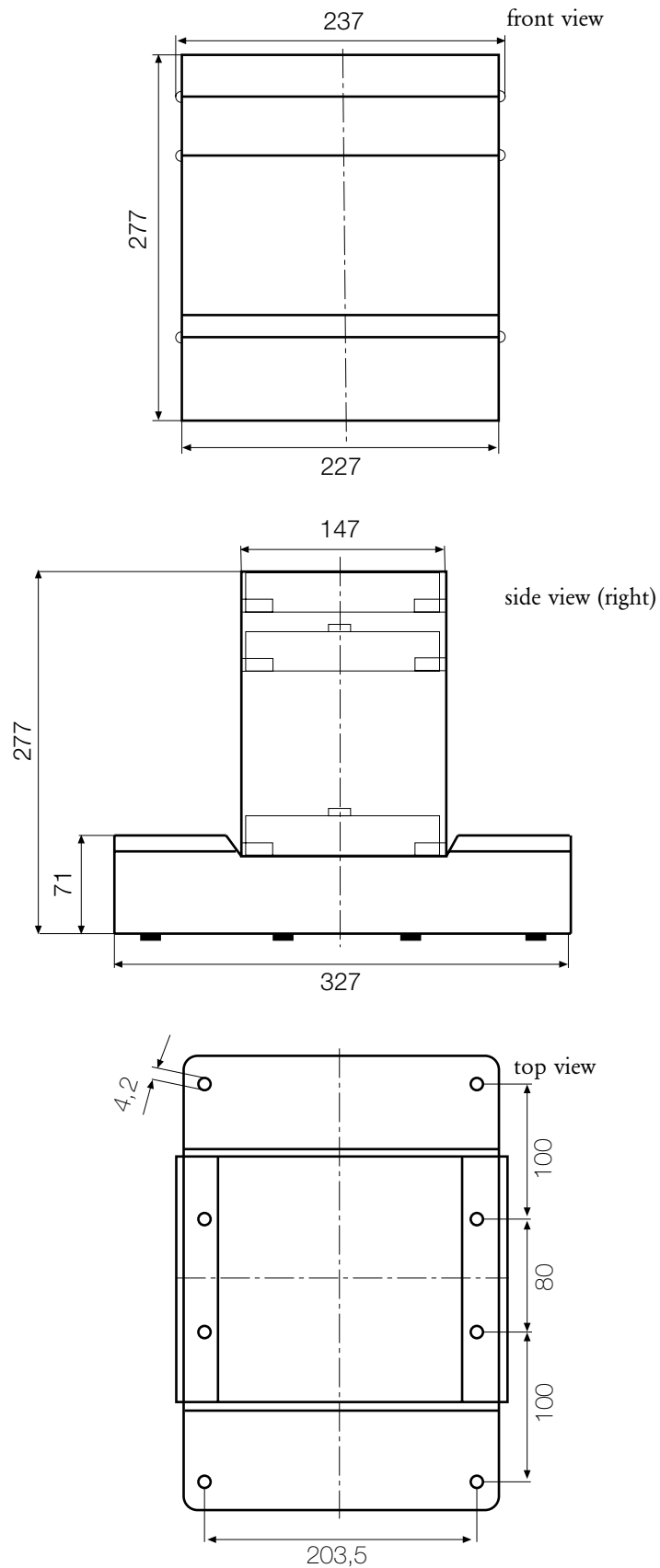

General dimensions according to DIN 7168, dimensions in mm

# Product description

## Dimensions coupling device AG5000

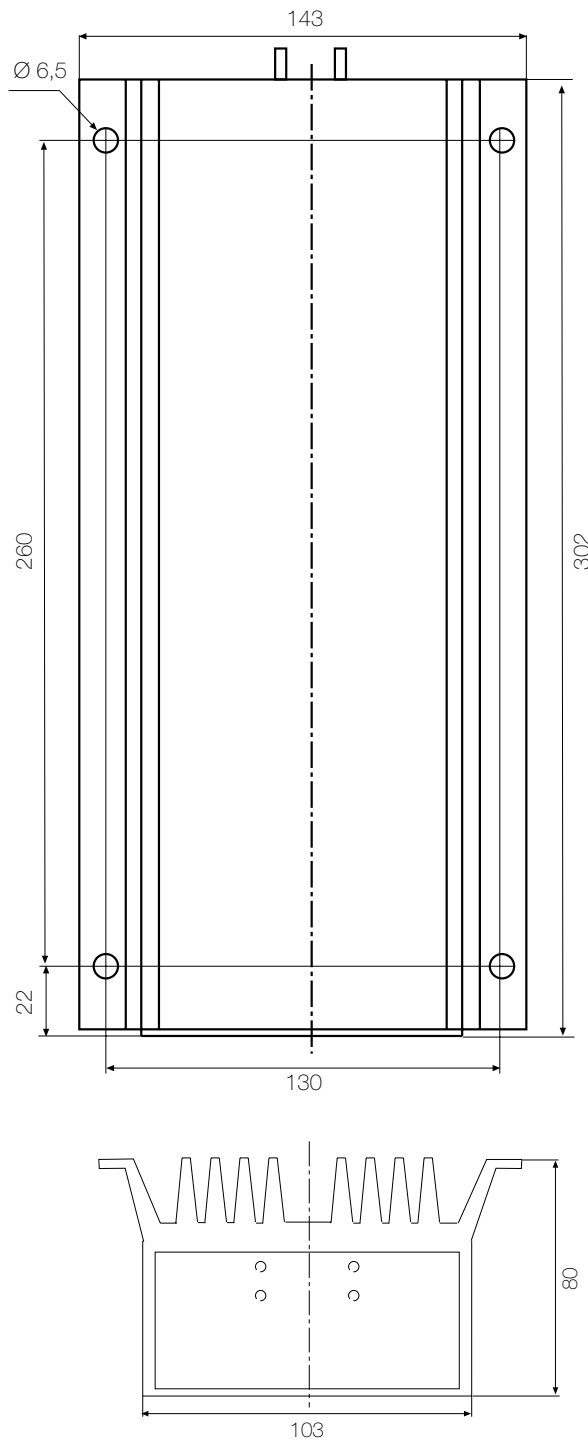

# Product description

## Wiring diagram

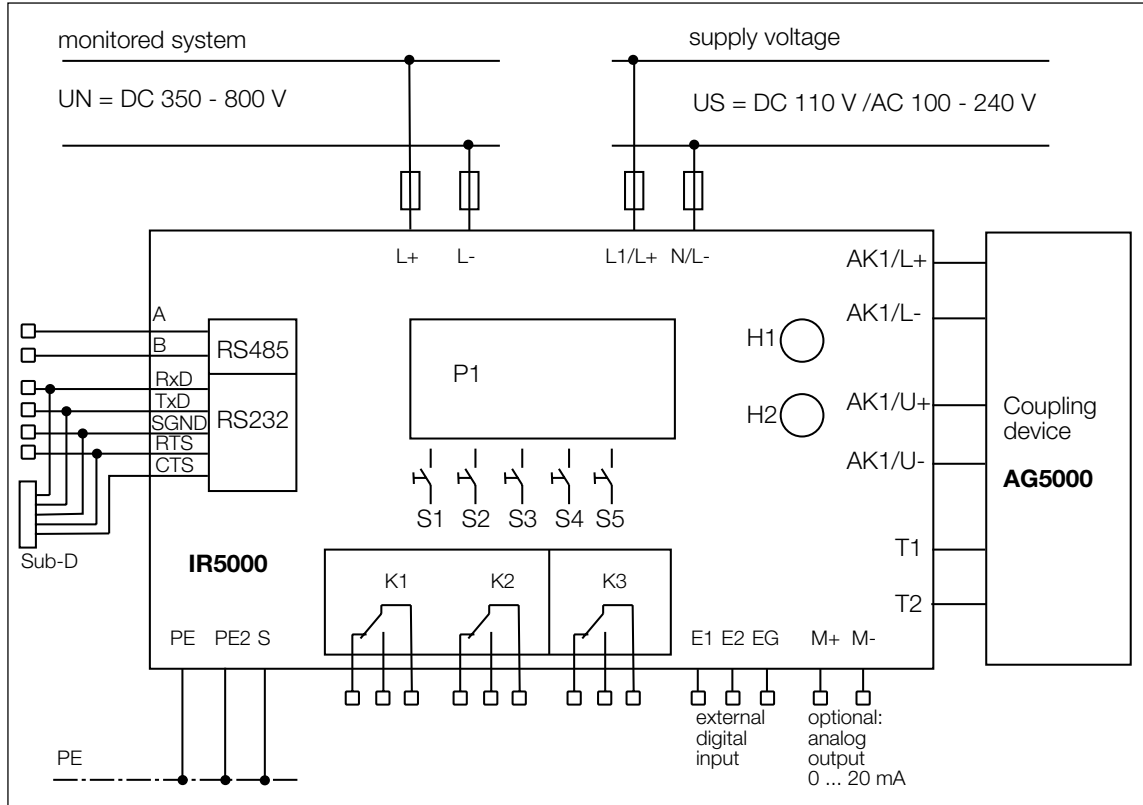

# Product description

Designation	Terminal designation	Explanation	Legend to wiring diagram
P1		LC display, 4 lines á 20 characters	
H1		alarm LED red, alarm L+	
H2		alarm LED yellow, alarm L-	
K1	11,12,11,14	alarm relay alarm L+, 1 change-over contact	
K2	21,22,21,24	alarm relay alarm L-, 1 change-over contact	
K3	31,32,31,34	alarm relay system fault, 1 change-over contact	
S1		UP-Taste	
S2		DOWN-key	
S3		RIGHT-key	
S4		LEFT-key	
S5		ENTER-key	
E1	E1	digital input 1, measurement suppression	
E2	E2	digital input 2, (without function at the moment)	
EG	EG	earth terminal of the digital inputs 1 and 2	
L+	L+	system coupling L+	
L-	L-	system coupling L-	
AK1/L+	AK1/L+	output L+ of coupling device AG5000	
AK1/L-	AK1/L-	output L- of coupling device AG5000	
AK1/U+	AK1/U+	input U+ of coupling device AG5000	
AK1/U-	AK1/U-	input U- of coupling device AG5000	
T1	T1	positive input temperature measuring of device AG5000	
coupling			
T2	T2	negative input temperature measuring of device AG5000	
coupling			
PE	PE	coupling PE (earth)	
PE2	PE2	control earth (connection monitoring)	
S	PE	connection for cable shielding	
A	A	output A RS485 interface	
B	B	output B RS485 interface	
M+	M+	analog output + (0...20 mA, linear)	
M-	M-	analog output - (0...20 mA, linear)	
RxD, TxD	RxD, TxD	output RS232 interface on the terminal strip	
SGND	SGND	and on 9-pole Sub-D connector (f)	
RTS, CTS	RTS, CTS		

# Product description

## Terminal strips

IR5000 is equipped with two separate terminal boxes. The cables are led into the terminal boxes using screwed cable glands (PG9 and PG11).

### Upper terminal box

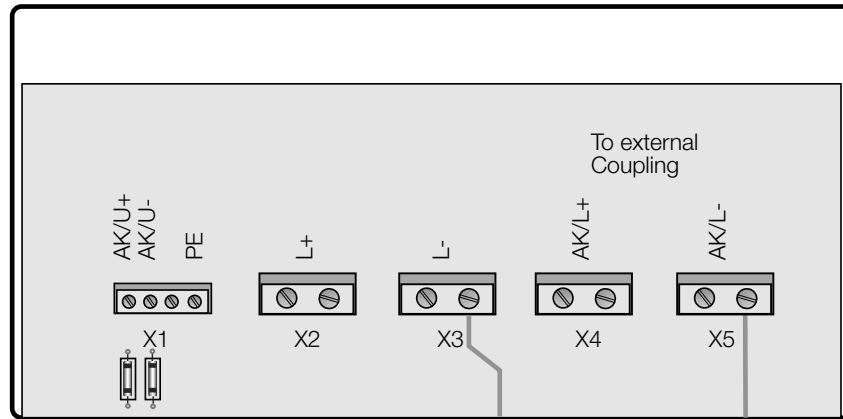

The upper terminal box is exclusively used for the coupling of the measuring circuit to the system to be monitored and the connection to the optional coupling device AG5000.

### Lower terminal box

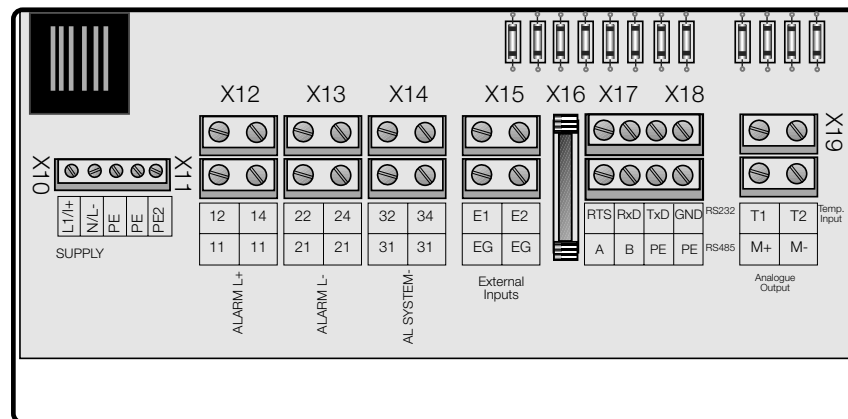

The lower terminal box is equipped with the strip terminals X10...X19. These terminals are used to connect the supply voltage, PE connections as well as all inputs and outputs.



## 5 Setting and operation

Operation as well as all the settings are carried out by means of the software using 5 function keys.

### Function keys

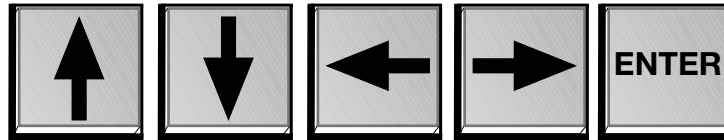

UP-key    DOWN-key    LEFT-key    RIGHT-key    ENTER-key

When operating under normal conditions, the main screen displays the currently applicable measuring values. For changing parameters or settings, the main menu has to be selected.

Once the power supply is switched on, the welcome screen appears displaying the manufacturer's name (BENDER), the device type, and the firmware version.

### Welcome screen

```

*****BENDER*****
*A-ISOMETER IR5000*
*VERSION L2.0/05.96*
| ENTER |
    
```

The welcome screen is displayed for about 5 seconds and then automatically changes to the main screen. If the ENTER-key is activated within this time, the main screen will be displayed immediately.

### Main screen

```

U- = 564 V UN = 620 V
RF- = 100kΩ RF+ = 10kΩ
AL- = 100kΩ AL+ = 10kΩ
Menue: | → | 08:37
    
```

The picture above shows a main screen typical for IR5000 during operation.

U- = 564 V	The currently applicable measuring value of the negative pole-to-earth voltage is 564 V
U <sub>N</sub> = 620 V	The current measured value of the nominal system voltage is 620 V
RF- = 100kΩ	The negative pole-to-earth insulation resistance is 100 kΩ (calculated value)
RF+ = 10 kΩ	The positive pole-to-earth insulation resistance is 10 kΩ (calculated value)
AL- = 100 kΩ	The pre-set response value for the negative fault is 100 kΩ
AL+ = 10 kΩ	The pre-set response value for the positive fault is 10 kΩ
Menue:   →	Press the RIGHT-key to change to the respective menu
08:37	System time of the IR5000 (real time clock)

## Setting and operation

---

The following picture shows a main menu indicating that the measurement suppression has been activated. Measurement suppression can be activated or deactivated by digital input 1. IR5000 is isolated from the system to be monitored during measurement suppression.

```
**** MEASURING ****
*** SUPPRESSION ***
***** ACTIVE *****
Menu: | → | 08:37
```

### Menus

IR5000 offers 10 different menus for setting and operation. Pushing the RIGHT-key from the main screen opens the screen with the menu selection.

```
1. MAIN SCREEN
2. RESPONSE VALUES
3. ALARM TIMING
| ↓ | | ENTER |
```

Of course, not all the menus can be presented within one four-line LC display. You can choose between 3 menus by scrolling the display via the UP and DOWN keys. The other menus can be selected by scrolling the DOWN key. In order to activate the desired menu, scroll the UP and DOWN keys and position the cursor on the respective digit. Then activate the menu by pushing the ENTER-key.

All menus are displayed in the following picture:

```
1. MAIN SCREEN
2. RESPONSE VALUES
3. ALARM TIMING
■ RELAY MODE
5. ALARM SYST. VOLT.
6. SERIAL INTERFACE
7. ENABLE MEASUREM.
8. TEMPERATURE
9. SET CLOCK
10.ABOUT
| ↑ ↓ | | ENTER |
```

## Setting and operation

After positioning the cursor on menu 1 MAIN SCREEN by means of the UP and DOWN keys and activating the ENTER-key, the already familiar screen appears.

### The individual menus

In menu 2 RESPONSE VALUES it is possible to set the response values for positive and negative faults separately.

### Setting the response values

```
1. MAIN MENU
2. AL+ = 100kΩ
3. AL- = 100kΩ
| ↓↑ | | ENTER |
```

By positioning the cursor on 1 MAIN SCREEN, the IR5000 links to the MAIN SCREEN for setting the response values. Selecting 2 (AL+) allows for setting the response value for positive faults.

```
1. MAIN MENU
2. AL+ = 100kΩ
3. AL- = 100kΩ
|↓|↑|←|→| | ENTER |
```

After selecting 2 AL+ by activating the ENTER-key, use the LEFT and RIGHT-key to select the respective digit you are going to change. Select the appropriate value by scrolling the UP and DOWN key. The digit can be changed in 1-unit steps. If you position the cursor on k of the dimension kΩ, for example, you can change the dimension from Ω into kΩ or vice versa by scrolling the UP and DOWN key.

Confirming with ENTER after finishing the modifications returns you to the previous screen. In the same way, the response value for the negative fault AL- can be changed.

Positioning the cursor onto 1 MAIN SCREEN and confirming with ENTER opens the MAIN MENU.

From the main menu select the submenu 3 ALARM TIMING for setting the delay time.

### Time response

```
1. MAIN MENU
2. DELAY-TIME: 10s
3. WINDOW-TIME: 50s
|↓|↑| | ENTER |
```

In the submenu 2 DELAY TIME, it is possible to set a delay time between 0 and 100 seconds for the alarm relays. To open this sub menu position the cursor onto 2 and confirm with ENTER.

## Setting and operation

1. MAIN MENU  
2. DELAY-TIME: █ 10s  
3. WINDOW-TIME: 50s  
↓ | ↑ | ← | → | ENTER

As shown in the picture above, the cursor is now positioned before the time display (10s). Now choose the new value by scrolling the UP and DOWN keys. This is possible in five-second steps. Confirming with ENTER accepts the selected value and returns you to the sub menus 1, 2 or 3. Proceed in the same way if you are going to set the value for WINDOW TIME. Here you can choose the value in 10-seconds steps between 10 and 300 seconds.

DELAY TIME and WINDOW TIME are dependent on each other. Accordingly some explanations:

If an insulation fault occurs the DELAY TIME starts running and stops when the pre-set delay time is reached unless the insulation fault has been cleared. The counter stops running as soon as the insulation fault is cleared within the running DELAY TIME.

The WINDOW TIME also starts running when an insulation fault is detected. Yet, unlike the DELAY TIME, the WINDOW TIME will not be interrupted if the insulation fault is cleared within this period.

The following diagram shows the correlation between fault detection and the different times.

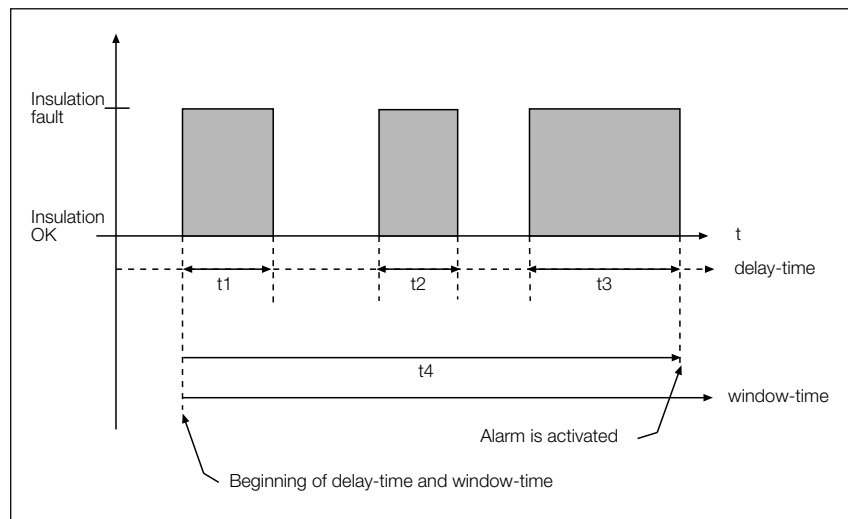

After detecting the insulation fault the DELAY TIME and WINDOW TIME start running. The pre-condition for the activation of the alarm relay is:

Activation if:

$(t1 + t2 + t3) > \text{delay-time} \text{ .AND. } (t4 < \text{window-time})$

### Important:

The pre-set value for the WINDOW TIME has always to be greater than the pre-set DELAY TIME.

## Setting and operation

If you are going to re-set an activated alarm proceed in the way as has been explained before, except the fact that the times without insulation faults are summarized. This is clearly shown in the diagram below:

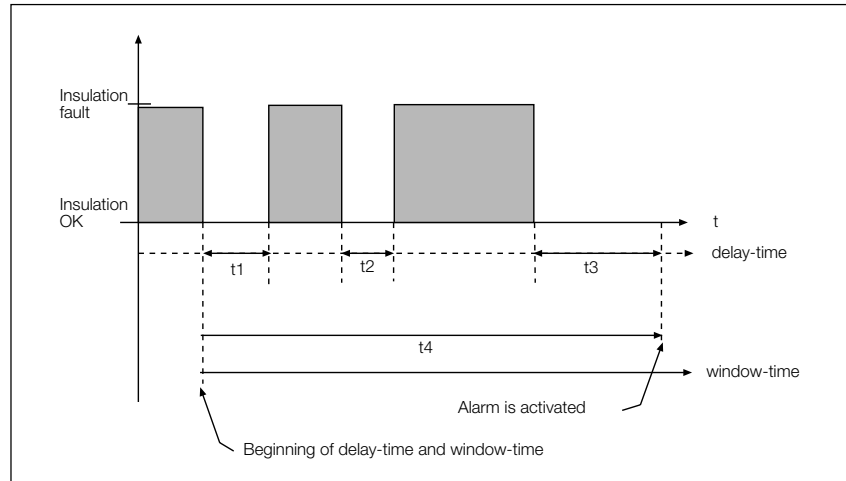

If an insulation fault occurs, a bar graph is displayed on the screen showing the elapsed time of the fault. The bar graph appears in the last line of the LC display whilst the other information and the actual time disappear.

### Indication of the time response

Note: The bar graph indication of the time elapse is only displayed during setting of alarm not during resetting of alarm.

```

U- = 350 V UN = 620 V
RF- = 100kΩ RF+ = 85kΩ
AL- = 100kΩ AL+ = 10kΩ
DELAY: L± ■■■■■■■■■■
    
```

After setting the DELAY TIME and WINDOW TIME confirm with ENTER to return to the main menu.

Select menu 4 RELAY MODE to set the operating principle of the two alarm relays. to positive resp. negative faults.

### Operating principle of the alarm relays

```

1. MAIN MENU
2. RELAY 1: N.CLOSED
3. RELAY 2: N.CLOSED
| ↓↑ | | ENTER |
    
```

## Setting and operation

### N/O or N/C operation

Optionally, N/O or N/C operation can be selected. Within the menus, the English terms N.CLOSED resp. N.OPEN are used:

N.CLOSED:	normally closed	=>	N/C operation
N.OPEN:	normally open	=>	N/O operation

N/C operation means: In normal condition, the respective alarm relay of the IR5000 is energized and is de-energized in fault condition.

N/O operation means: In normal condition, the respective alarm relay of the IR5000 is de-energized and energized in fault condition.

For changing the operating principle of the alarm relay, select the respective relay by using the UP and DOWN keys. RELAY1 is the alarm relay for insulation faults at the positive conductor (positive fault), RELAY2 is the alarm relay for insulation faults at the negative conductor (negative fault).

```
1. MAIN MENU
2. RELAY 1:  N.CLOSED
3. RELAY 2:  N.CLOSED
| ↓↑ | | ENTER |
```

If, for example, the alarm relay 2. RELAY 1 is selected for the positive fault and confirmed with ENTER, the cursor jumps to line 2. RELAY 1 and is positioned before the designation N.CLOSED, as shown in the picture above.

By scrolling the UP and DOWN keys it is possible to select between N.CLOSED and N.OPEN. Confirming with ENTER returns you to the previous mask. From there you will return to the main menu.

### Setting the threshold of the voltage



Select 5 ALARM SYST. VOLTAGE from the main menu to set the threshold of the system voltage. If the value falls below the set threshold of the system voltage, it will be signalled by the alarm relay K3 (N/C operation). Thresholds of 350 V and 100 V can be selected. **Attention: if the value falls below the set threshold in the event of an insulation fault, no alarm will be actuated.** Setting the threshold to 100 V does not change the permissible operating range of IR5000 from 350 to 800 V for the insulation monitoring function.

```
1. MAIN MENU
2. MIN. ALARM SYSTEM
  VOLTAGE: 350V
| ↑ | | ENTER |
```

By positioning the cursor onto sub menu 2 and confirming with ENTER, the cursor jumps to line 3 and is positioned in front of the value of the voltage.

```
1. MAIN MENU
2. MIN. ALARM SYSTEM
  VOLTAGE:  350V
| ↑↓ | | ENTER |
```

By scrolling the UP and down keys either 350 V or 100 V can be selected. ENTER confirms the selected value and returns you to the previous menu.

## Setting and operation

Select the sub menu 6 SERIAL INTERFACE from the main menu for the configuration of the serial interfaces.

### Setting the serial interface



Selecting 2 RS232 BAUD changes the baud rate of the RS232 interface. The baud rate can be set between "No" (interface deactivated) and 19200 baud.

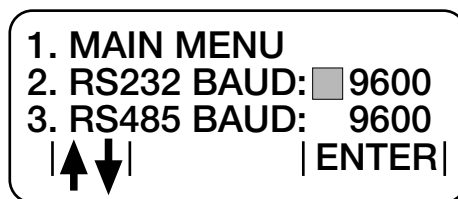

By scrolling the UP and DOWN keys the desired baud rate can be selected. Confirming the selected value with ENTER returns you to the previous menu. In the same way the baud rate of the RS485 interface can be set.

If you are going to adjust the digital input 1 (connection terminals E1 and E6), select the sub menu 7 ENABLE MEASUREM. from the main menu.

### Adjusting digital input 1

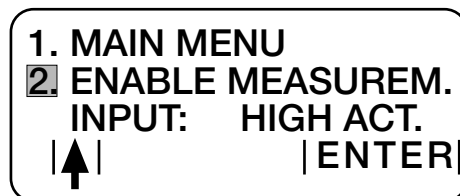

After selecting the sub menu 2 ENABLE MEASUREM INPUT and confirming with ENTER select between NOT ACTIVE, HIGH ACTIVE and LOW ACTIVE by scrolling the UP and DOWN keys.

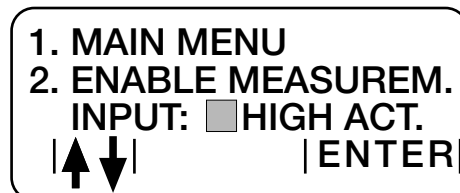

Explanation:

NOT ACTIVE

The external digital input 1 (E1/E6) is not activated. The device is working independently of the signal at the external input.

HIGH ACTIVE

A D.C. voltage of 24 V ( $\pm 25\%$ ) activates the device. If no DC voltage is detected the internal measuring suppression will be activated, the measurement is disabled. The LC display indicates MEASURING SUPPRESSION ACTIVE.

# Setting and operation

**LOW ACTIVE** A D.C. voltage of < 5 V at E1/EG activates IR5000. If a high signal (24 V) is detected the measurement will be disabled.

## Temperature display

IR5000 measures the temperature inside its housing as well as the temperature inside the coupling device. In this way, internal defective components (in so far as they cause a temperature rise) or overvoltages existing for a long time can be detected. The measured values are used to compensate the response of the measuring resistors to temperature changes. Therefore it is recommended to check the temperature regularly.

Select the menu item 8 TEMPERATURE from the main menu to check the temperature. This menu displays both the internal temperature and the temperature inside the coupling device. It is not possible to make any settings. The measured values of the temperature are transmitted via the serial interfaces RS232 and RS485 as part of the data record.

```
1. MAIN MENU
TEMP. HOUSING: + 25°C
TEMP. COUPL.: + 50°C
| ENTER |
```

## Setting date and time

Select the submenu 9 SET CLOCK from the main menu for setting the real-time clock. Date and time can be set.

```
1. MAIN MENU
2. DATE: 30/06/96
3. TIME: 07:48
| ↓↑ | | ENTER |
```

Position the cursor onto the submenu 2.DATE and confirm with ENTER for setting the date. The cursor will move to the array DATE (in this picture the 30th).

```
1. MAIN MENU
2. DATE: 30/06/96
3. TIME: 07:48
|↓|↑|←|→| | ENTER |
```

By scrolling the UP and DOWN keys the date can be changed upwards or downwards. Using the LEFT and RIGHT keys you can move to the month display resp. to the year display. There you can change the digits by scrolling the UP and DOWN keys.

Confirming with ENTER returns you to the previous menu. Now you have the possibility of positioning the cursor onto the sub menu 3 TIME in order to change the time in the same way. It is also possible to change the indication of hours and minutes.



# Setting and operation

---

Selecting the last sub menu 10.ABOUT opens a screen with information about the manufacturer (BENDER), designation of the device and the software version (identical with the welcome screen).

If problems arise or information about IR5000 is required, the first thing the user wants to know is the software version. Information can be interrogated from this sub menu.

## Software version

```
*****BENDER*****  
*A-ISOMETER IR5000*  
*VERSION L2.0/05.96*  
| ENTER |
```

The settings described in this chapter allow for optimal adaptation to the individual application of the system. Before starting operation please check if the factory settings suit your needs. If necessary make the respective changes. The following parameters are pre-set:

## Factory settings

Response values (Menu 2 RESPONSE VALUES)	1 k $\Omega$ / 1 k $\Omega$
Response times (Menu 3 ALARM TIMING)	Delay-time: 10 s, Window-time: 50 s
Relay mode (Menu 4 RELAY MODE)	K1 and K2: N/O operation; K3: N/C operation (fixed setting)
Alarm indication voltage (Menu 5 ALARM SYST. VOLT.)	DC 350 V
Serial interfaces (Menu 6 SERIAL INTERFACE)	9600 baud. Further parameters are 8N1 (not adjustable).
Digital input 1 (Menu ENABLE MEASUREMENT.)	NOT ACTIVE

## 6 Wiring and commissioning

---

Wiring and commissioning may only be carried out by qualified personnel in consideration of the current safety regulations.



First fix the IR5000 to the wall using the intended mounting holes in the enclosure. Then all the electrical connections can be carried out.

**Attention: Make sure that the installation is voltage-free before connecting the device!**

Follow these steps :

- Connect the PE conductor to the PE and PE2 terminals.
- If you use the coupling device AG5000, connect the leads of the coupling device to the terminals AK/L+, AK/L-, AK/U+, AK/U-, T1 and T2.  
Attention: Be sure not to mix up the connecting leads !  
The connecting leads of the coupling device AG5000 are labelled.
- Connect the contacts of the alarm relays, the external digital input 1 and the serial interface.
- Connect the positive pole of the IT system to the IR5000 terminal L+.
- Connect the negative pole of the IT system to the IR5000 terminal L-.  
Attention: For short-circuit protection, the connections to the system coupling L+ and L- have to be equipped with a protective device (a fuse of 6 A is recommended).
- Connect the supply voltage to the IR5000 terminals L1/L+ and N/L-.  
For short-circuit protection, the connection to the supply voltage has to be equipped with a protective device according to IEC 60364-4-473 (a fuse of 6 A is recommended).
- Switch on the supply voltage.
- If necessary, make the respective adaptations via software (described in chapter SETTING AND OPERATION).
- Connect the system voltage. After approx. 10 seconds a screen appears displaying the measuring values.



**Important note:**

**Be sure not to disconnect the PE conductor from the system to be monitored unless all other wires are disconnected.**

# Wiring and commissioning

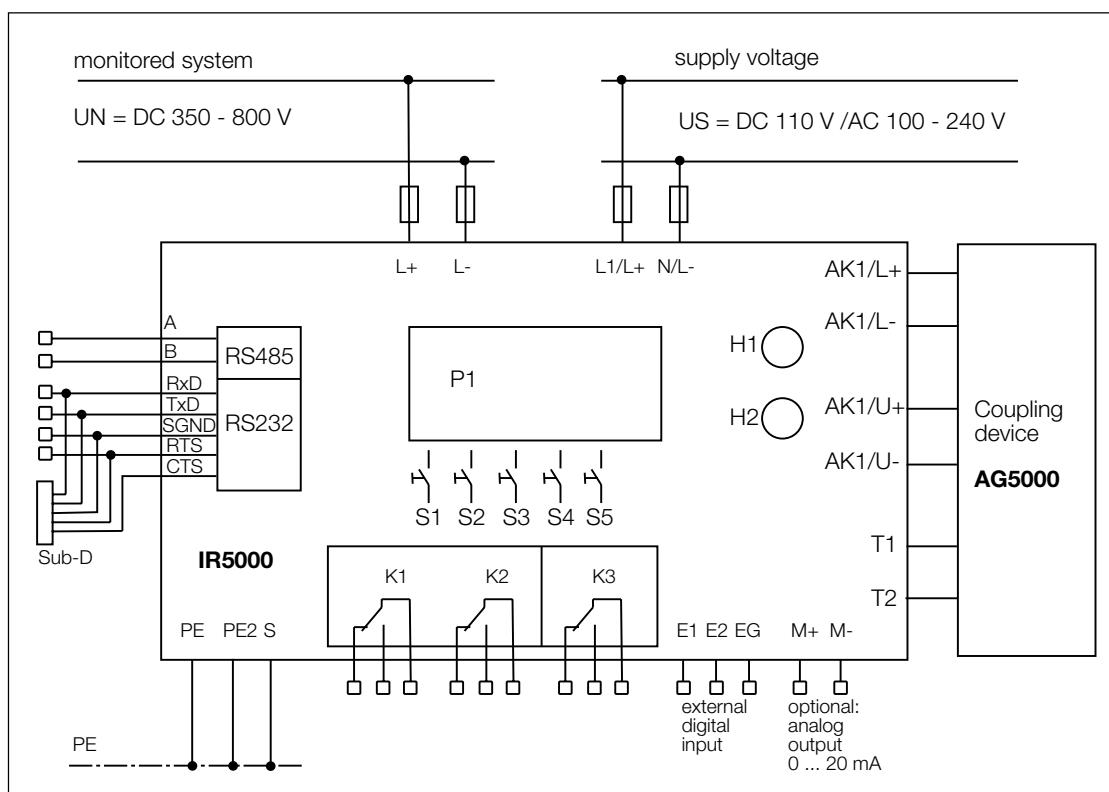

Designation	Terminal designation	Explanation
P1		LC display, 4 lines à 20 characters
H1		Alarm LED red, alarm L+
H2		Alarm LED yellow, alarm L-
K1	11,12,11,14	Alarm relay alarm L+, 1 change-over contact
K2	21,22,21,24	Alarm relay alarm L-, 1 change-over contact
K3	31,32,31,34	Alarm relay system fault, 1 change-over contact
S1		UP key
S2		DOWN key
S3		RIGHT key
S4		LEFT key
S5		ENTER key
E1	E1	Digital input 1, measurement suppression
E2	E2	Digital input 2, (without function at the moment)
EG	EG	Earth terminal of digital inputs 1, 2
L+	L+	System coupling L+
L-	L-	System coupling L-
AK1/L+	AK1/L+	Output L+ of coupling device AG5000
AK1/L-	AK1/L-	Output L- of coupling device AG5000
AK1/U+	AK1/U+	Input U+ of coupling device AG5000
AK1/U-	AK1/U-	Input U- of coupling device AG5000
T1	T1	Positive input, temperature measuring of coupling device AG5000
T2	T2	Negative input, temperature measuring of coupling device AG5000
PE	PE	Coupling PE (earth)
PE2	PE2	Control earth (connection monitoring)
S	PE	Connection for cable shielding
A	A	Output A RS485 interface
B	B	Output B RS485 interface
M+	M+	Analog output + (0 ... 20 mA, linear)
M-	M-	Analog output - (0 ... 20 mA, linear)
RxD, TxD	RxD, TxD	Output RS232 interface on the terminal strip
SGND	SGND	and on 9-pole Sub-D connector (f)
RTS, CTS	RTS, CTS	

# Wiring and commissioning



**Important note:**

to fulfil the EMC requirements it is necessary to mount ferrite cores to the wires for the supply voltage and the earth wires. The bigger ferrite core is for the power supply (terminals L1/L+ and N/L-), the smaller ferrite core is for the earth wires PE and PE2. All of these terminals are in the lower terminal box. Please install the ferrite core according to the following diagram:

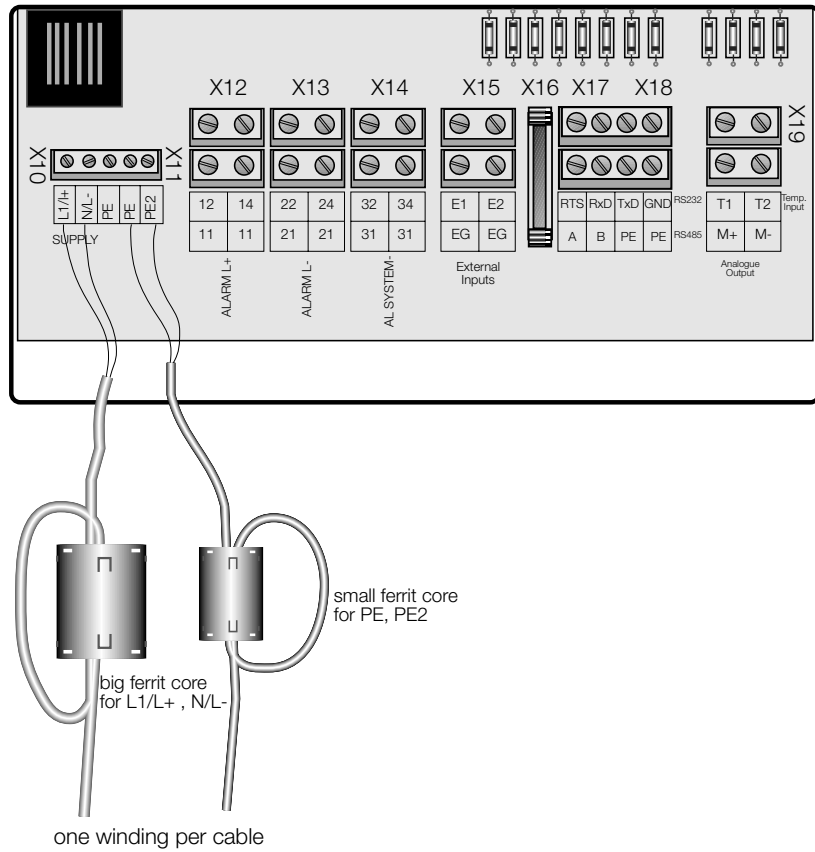

# Wiring and commissioning

---

## Error messages

Various error messages may occur during operation. Error messages are indications of internal or external faults of the IR5000 excluding the response of the device when the pre-set response value of the insulation resistance has been exceeded.

CRITICAL ERRORS are signalled when certain internal errors occur. CRITICAL ERROR means, for example, that the system voltage has fallen below the pre-set minimum value (<350 V resp. < 100 V DC).

```
*****  
*          *  
* CRITICAL ERROR *  
*   Un < 350 V   *  
*          *  
*****
```

As shown in the picture above, IR5000 provides detailed descriptions about the nature of error. In this case, it is recommended to measure the system voltage.

From the display CRITICAL ERROR you have the possibility to get to the setting menu by activating the RIGHT key.

```
**** MEASURING ****  
*** SUPPRESSION ***  
***** ACTIVE *****  
Menue: | → | 08:37
```

The indication MEASURING SUPPRESSION ACTIVE shows that the measuring suppression has been activated via the digital input 1 (E1/EG).

# Wiring and commissioning

## System errors, CRITICAL ERRORS

If one or more CRITICAL ERRORS occur, the relay K3 energizes and the corresponding error (system error) will be displayed. IR5000 interrupts its measurements when a CRITICAL ERROR occurs. The error code will be output via both serial interfaces.

All CRITICAL ERRORS with code and short description are listed in the table below:

Code NO.	System error	Short description
----------	--------------	-------------------

1	RTC-Error	Error of the internal real-time clock of the microcontroller. IR5000 defective!
2	ADC-Error	Error in the analog/digital converter of the AD unit. IR5000 defective!
3	Display-Error	Error of the display or its control circuit. IR5000 defective.
4	I <sup>2</sup> C Error	Error of the non-volatile memory. IR5000 defective!
5	Temperature Error	Temperature inside the casing of IR5000 or the external coupling device AG5000 is too high. Measurements will be stopped as soon as the temperature inside the coupling device exceeds 150 °C.
6	No-PE	There is no PE connection to IR5000. Touching the device may result in harmful effects to persons. By all means, the device must be checked by a qualified electrician.
7	Polarity	Wrong polarity of the network coupling L+/L. Check system coupling!
8	Low-UN	System voltage is too low! System voltage is below the pre-set value MINIMUM SYSTEM VOLTAGE ALARM. Check system voltage and connection.



# Wiring and commissioning

## Indication of asymmetrical faults

The chapter FUNCTIONAL PRINCIPLE already refers to the fact that symmetrical and asymmetrical insulation faults have to be considered separately. In particular, asymmetrical faults have to be considered.

If the ratio between the higher and the lower insulation value is greater than 50, the measured value for the higher insulation resistance insulation will not be displayed directly. Since in this case the limits of accuracy have been exceeded, the only indication is:  $> 50 \times \text{RF-}$ .

Example:

UN- = 10 V UN = 700 V  
 RF- = 20Ω RF+ > 1kΩ  
 AL- = 50kΩ AL+ = 50kΩ  
 Menu: | → | 08:45

If the insulation resistance of one conductor falls below 5 Ω, the shift voltage of the other conductor is too low to calculate any value. In this case, the LC display indicates XXXX for this high resistance insulation fault.

Different insulation faults and the respective indications are listed in the table below:

Value of insulation fault		Indication		Remarks
RF+	RF-	RF+	RF-	
20Ω	100Ω	20Ω	100Ω	Ratio of positive/negative faults is < 50
20Ω	15kΩ	20Ω	>1kΩ	Ratio of positive/negative faults is > 50
15kΩ	20Ω	>50kΩ	20Ω	Ratio of positive/negative faults is > 50
1kΩ	80kΩ	1kΩ	>50kΩ	Ratio of positive/negative faults is >50
80kΩ	1kΩ	>50kΩ	1kΩ	Ratio of positive/negative faults is >50
3Ω	1kΩ	3Ω	xxxx	RF+ < 5 Ω, => RF value cannot be determined
1kΩ	2Ω	xxxx	2Ω	RF- < 5 Ω, => kRF value cannot be determined
4Ω	3Ω	4Ω	3Ω	Symmetrical fault: although both of the values are < 5 Ω the are indicated correctly

# Wiring and commissioning

---

## Data output

Data determined by measuring and calculating are output via the interfaces RS 232 and RS 485. By means of appropriate programs (e.g. ISODATA for IR5000) data can be indicated and evaluated.

The following values are available via both serial interfaces:

AL+	Response value positive fault
AL-	Response value negative fault
MeasCount	Internal counter calculating the number of measuring passes for each valid measuring
RF	Total insulation resistance (+ and -) in parallel
RF+	Insulation resistance, positive conductor against PE
RF-	Insulation resistance, negative conductor against PE
UN	Voltage of the system being monitored
UL+	Shift-voltage, positive conductor against PE
UL-	Shift-voltage, negative conductor against PE
Alarm L+	Alarm, relay K1
Alarm L-	Alarm, relay K2
Contact Rel.1	Operating mode of alarm relay 1
Contact Rel.2	Operating mode of alarm relay 2
Temp-Int	Temperature inside the casing of IR5000
Temp-Ext	Temperature inside the coupling device AG5000
Coupling No	Coupling being switched on (High/Low)
Meas. En/Dis	Measurement suppression active/passive
Time	Time of day
Date	Date
Failure-Code	Code of internal CRITICAL ERROR
Checksum	Checksum of the transmitted data

A semicolon (;) is transmitted as a separator between data. At the beginning of a data record a STX and at the end of a data record an ETX (End of text, 03Hex) will be transmitted.

Below an example of a data record:

```
AL+;AL-;MeasCount;RF;RF+;RF-;UN;UL+;UL-;AlarmL+;AlarmL-;  
ContactRel1;ContactRel2; Temp-Int; CouplingNo; Meas.En/Dis; Time; Date;  
FailureCode; Checksum;  
  
001000; 001000; 001; 000796; 000803; 090000; 569; 005; 564; 1; 0; 1; 0; +30;  
+40; LOW;  
ME; 09:32 21/06/96; 02; 127;
```



## 7 Technical data

### Insulation coordination acc. to IEC 60664-1:

Rated insulation voltage	DC 800 V
Rated impulse withstand voltage/contamination level	8 kV/3
Dielectric test acc. to IEC 60255	4 kV

### System being monitored:

Rated mains voltage $U_N$	DC 350...800 V
Operating range $U_N$	DC 100...1100 V

### Supply voltage:

Supply voltage $U_S$ AC	AC 50...60 Hz 100...240 V
Operating range $U_S$ AC	0.9...1.1 $U_S$
Supply voltage $U_S$ DC	d.c. 110 V
Operating range $U_S$ DC	0.8...1.2 $U_S$
Max. power consumption	30 W max.

### Response values:

Response value $R_{ALARM}$	5 $\Omega$ ...100 k $\Omega$
----------------------------	------------------------------

**For response values <1000  $\Omega$  a coupling device AG5000 must be used.**

Alarm indication threshold voltage exceeded	350 or 100 V
Max. system leakage capacitance	10 $\mu$ F

### Response times:

Delay time	0...100 s
Window time	0...300 s

### Measuring circuit:

Internal resistance DC $R_{i-plus}/R_{i-minus}$	1 M $\Omega$ /500 k $\Omega$
Internal resistance DC $R_{i-plus}/R_{i-minus}$ with AG5000	10 k $\Omega$ /5 k $\Omega$

### Relay outputs

Contact circuit	
Switching components	3 change-over contact
Contact class acc. to DIN IEC 60255 Teil 0-20	IIB
Rated contact voltage	AC 250 V/DC 300 V
Admissible number of operations	12000 cycles
Limited making capacity	UC 5 A
Limited breaking capacity	
at AC 230 V and $\cos \phi = 0.4$	AC 2 A
at DC 220 V and $L/R = 0.04$ s	DC 0.2 A
Operating principle, K1 and K2, selectable	N/O / N/C operation
Pre-set by factory, K1 and K2	N/O operation
Operating principle K3	N/C operation
<b>Serial interfaces</b>	RS 232 and RS 485

### Outputs

*analog output M+/M-	0...20 mA, linear
----------------------	-------------------

### Inputs

Digital input 1 (E1/EG)	selectable, DC 24 V or DC 5 V
Digital input 2 (E2/EG)	without function at the moment

\* ) see diagram on page 35

Supplementary information on switching elements:

The insulation condition between the relays is:

basic insulation 230 V, protective separation < 150 V

# Technical data

---

## Type tests

Test of the Electromagnetic Compatibility (EMC):

Immunity for industrial environments acc. to IEC 61000-6-2:

Electrostatic discharge immunity test acc. to IEC 61000-4-2 severity degree 3

Radiated, radio-frequency, electromagnetic field

immunity test EM acc. to IEC 61000-4-3 severity degree 3

Burst immunity test acc. to IEC 61000-4-4 severity degree 3

Surge immunity test acc. to IEC 61000-4-5 severity degree 3

Immunity to conducted disturbances,

induced by radio-frequency fields acc. to IEC 61000-4-6 severity degree 3

Power frequency magnetic field

Immunity test acc. to IEC 61000-4-8 severity degree 3

Voltage dips, short interruptions and voltage

variations, immunity tests acc. to IEC 61000-4-11 severity degree 3

Emissions acc. to EN 50081-2:

Emissions acc. to EN 55011/CISPR11 class B

Mechanical tests:

Shock resistance acc. to IEC 6068-2-27 15 g/11 ms

Bumping acc. to IEC 6068-2-29 40 g/6 ms

Vibration strength acc. to IEC 6068-2-6 10...150 Hz/0.15 mm - 2g

## Environmental conditions

Ambient temperature, during operation -15°C...+55°C

Storage temperature range -40°C...+70°C

Climatic class acc. to IEC 60721 3K5

(except condensation and formation of ice)

## General data

Operating mode continuous operation

Mounting any position

Connection terminals with self-lifting clamp-washers

Cross sectional area of connecting cable, single wire 0.2...4 mm<sup>2</sup>

Cross sectional area of connecting cable, flexible 0.2...2.5 mm<sup>2</sup>

(AWG 24 12)

Casing 19" casing 30 TE /4 HE for wall-mounting

Protection class acc to EN 60529 IP 65

## Ordering details

IR5000 Art. No. 91 059 004

AG5000 Art. No. 98 039 002

## Analog output IR5000 (0-20 mA)

### Analog output IR5000

The IR5000 provides one analog output of 0...20 mA which is specified in the table below:

### Current resistance table

I/mA	Rf/kΩ	I/mA	Rf/kΩ	I/mA	Rf/kΩ
0.0	200	7.0	130	14.0	60
0.5	195	7.5	125	14.5	55
1.0	190	8.0	120	15.0	50
1.5	185	8.5	115	15.5	45
2.0	180	9.0	110	16.0	40
2.5	175	9.5	105	16.5	35
3.0	170	10.0	100	17.0	30
3.5	165	10.5	95	17.5	25
4.0	160	11.0	90	18.0	20
4.5	155	11.5	85	18.5	15
5.0	150	12.0	80	19.0	10
5.5	145	12.5	75	19.5	5
6.0	140	13.0	70	20.0	0
6.5	135	13.5	65		

### Diagram current output IR5000

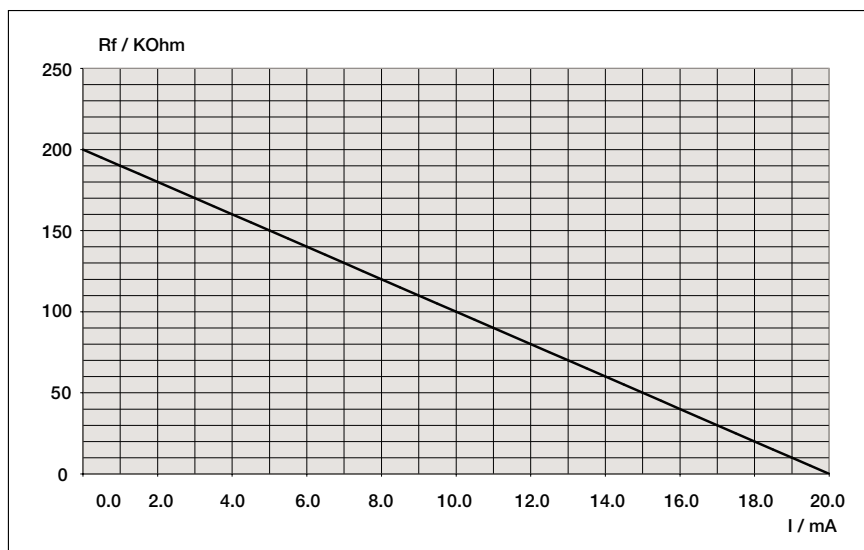

Diagram: current output 0 ... 20 mA

### Calculating formula IR5000

1 kΩ is 100 μA

$$R_f = \frac{I/\text{mA}}{20 \text{ mA}} \times 200 \text{ k}\Omega$$

## 8 ISODATA for IR5000

---

Every 10 seconds the insulation monitoring device IR5000 transmits a data record of the present measuring values via the serial interfaces RS232 and RS485. These data records can be read and stored into files using the software ISODATA for IR5000. Since ASCII characters are transmitted and stored, it is quite easy to transfer data into evaluating programs. Within the evaluating programs statistical and graphical data acquisition as well as long-time evaluation are possible.

ISODATA is a program based on the evaluation of ASCII characters and therefore a minimum of hardware components is required.

Pre-conditions to operate ISODATA are:

- an IBM compatible personal computer with a 8086, 80286, 80386 processor, Pentium or Pentium Pro
- 640 KB main memory, at least
- a hard disk providing 5 MB storage
- a 3.5" floppy disk drive with high type density (HD)
- VGA or HGA graphics adapter and monitor
- operating system MS-DOS 3.3 or higher

For installation, insert the installation disk into the respective PC drive. Select this drive and call up the installation program by typing INSTALL and confirming with ENTER.

On drive C an ISODATA directory will be created to which all the necessary program parts will be copied. Within this ISODATA directory a sub directory DATA will be created where the files with the entire measuring data are saved later on. Two demo files IR5000.001 and IR5000.002 including details on data and file structure will be copied to that directory during installation.

After successful installation change to hard disk C: and there to the directory ISODATA (cd isodata). From here open the program ISODATA.

ISODATA welcomes you with the starting screen. Select the device the measuring values are transferred from. You can choose between IR5000 and PR4000.

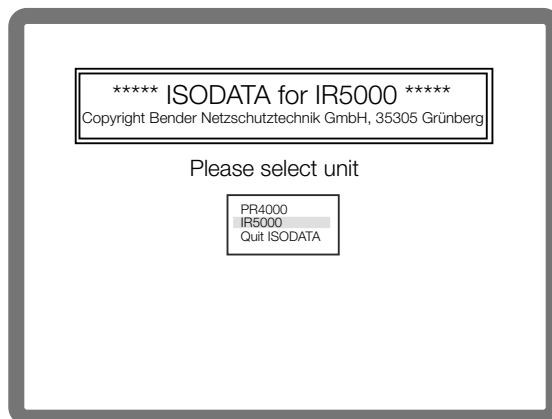

After selecting the device, the file name under which the measuring data are to be stored for this session has to be input. The file name may be changed but not the file extension.

### Hardware pre-conditions

### Program start

# ISODATA für IR5000

## File size

The pre-set file name is IR5000. If there already exists a file with the same name, do not change this name but increase the file extension by one (IR5000.001, IR5000.002 etc.).

Since every 10 seconds a new data record of measuring values is transmitted by IR5000, the files grow quite fast. ISODATA writes files up to the size of 1.4 MB. If this size has been reached another file with the same name and an extension file increased by one will be created. Again data are written into this new file until 1.4 MB are reached or the session will be aborted by the user. Since the file size is below 1.4 MB, it is possible to save this file to a 3.5" disk (HD format).

## The main screen

After entering a new file name or confirming the pre-set name, the main screen appears.

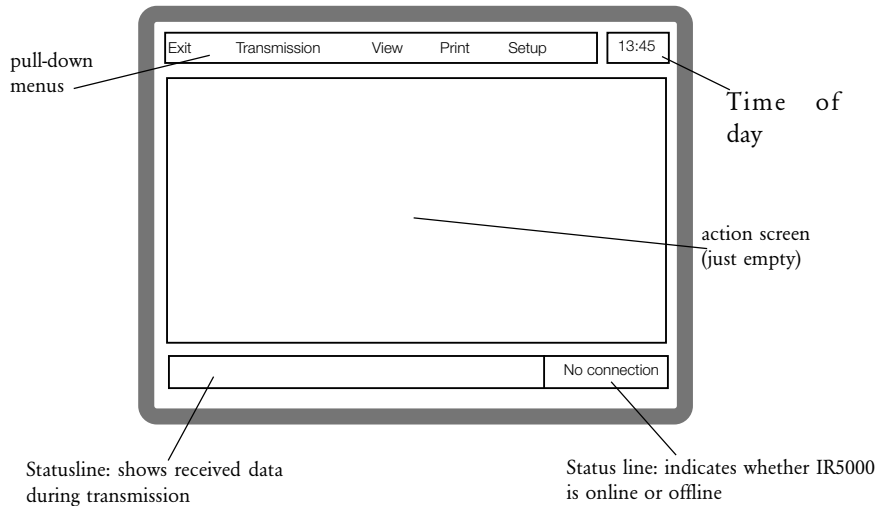

Optionally, the menu EXIT, TRANSMISSION, VIEW, PRINT and SETUP are available. Typing in the first letter of the respective menu activates the pull-down menu that allows for selecting the sub menu.

## The submenus

Selecting the menu EXIT opens the following pull-down menu:

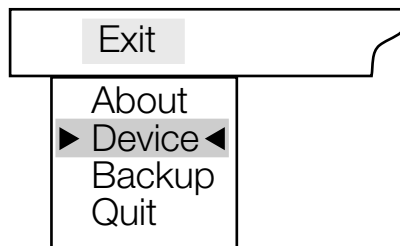

# ISODATA for IR5000

The submenus of EXIT contain the following program functions

- About** Information window indicating the program name, the program version and the manufacturer.
- Device** Informs you which BENDER device is connected. This indication is identical with the device selected in the starting screen.
- Backup** Saving of a data file from the sub directory DATA to a 1.4 MB disk. The file to be saved will be selected from all data existing in the subdirectory DATA.
- Quit** End of ISODATA, quitting the program.

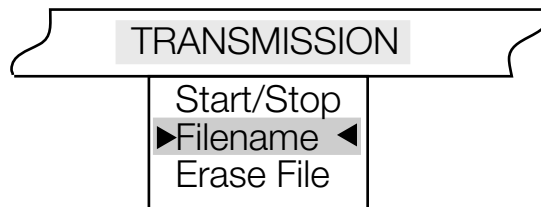

The menu Transmission includes the following submenus:

- Start/Stop** Starting and stopping (during transfer) the data transfer between IR5000 and ISODATA.
- Filename** Changing the filename is not possible except when changing the Bender device.
- Erase File** The file to be erased can be selected from a subdirectory of the selection box.

Starting data transfer via the submenu START/STOP opens a screen indicating the transmitting values.

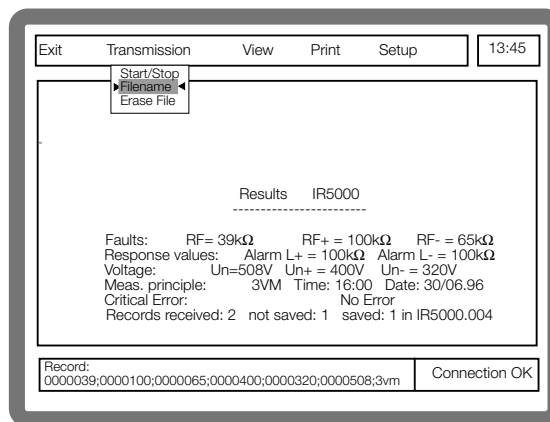

# ISODATA for IR5000

Activating the submenu VIEW loads an existing data file displaying the measuring values as ASCII dump.

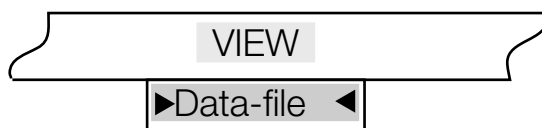

The measuring values are indicated in the following order:

AL+	Alarm positive fault
AL-	Alarm negative fault
RF	Total insulation resistance, total of parallel faults
RF+	Insulation fault positive conductor against PE
RF-	Insulation fault negative conductor against PE
UN	Voltage of the system being monitored
UL+	Shift voltage positive conductor against PE
UL-	Shift voltage negative conductor against PE
Alarm L+	Alarm indication alarm relay K1
Alarm L-	Alarm indication alarm relay K2
Temp-Int	Temperature inside the IR5000 casing
Temp-Ext	Temperature inside the AG5000 coupling device
Coupling no.	activated coupling (High/Low)
Meas. En/Dis	Measurement suppression active/passive
Time	Time of day
Date	Date
MeasCount	Internal counter for the number of measuring passes for one valid measurement
RecCount	Counter for the number of identical insulation fault values RF (corresponding to the setting Reference value)
Failure-Code	Code of the internal CRITICAL ERROR

**001000;001000;000796;000803;090000;569;005;564;1;0;1;0;+030;+040;LOW;  
ME;09:32;21/06/96;001;001;02;**

Data string	Explanation
001000;	AL+ in $\Omega$
001000;	AL- in $\Omega$
000796;	RF in $\Omega$
000803;	RF+ in $\Omega$
090000;	RF- in $\Omega$
569;	UN in V
005;	UL+ in V
564;	UL- in V
1;	Alarm L+, alarm relay K1 switches
0;	Alarm L-, alarm relay K2 does not switch
1;	Alarm relay K1 in N/O operation
0;	Alarm relay K2 in N/C operation
+030;	Temperature inside the casing is + 30°C
+040;	Temperature inside the coupling device is + 40°C
LOW ;	Coupling No is LOW, a D.C. voltage of < 5 V D.C. at digital input activates the measurement
ME;	Meas. Enabled, measurement suppression is active
09:32;	Time of day is 9:32
21/06/96;	System date is 21.06.1996
001;	MeasCount is 1
001;	RecCount is 1
02;	CRITICAL ERROR No. 02 has occurred

# ISODATA for IR5000

---

Activating the submenu PRINT outputs the existing data file to a connected printer.

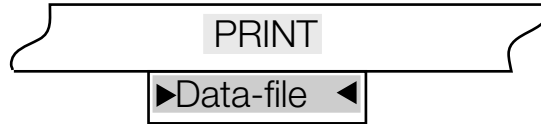

Data will be printed as ASCII characters. The print-out corresponds to the format indicated in the submenu VIEW.

The submenu SETUP allows for setting all the parameters of the program.

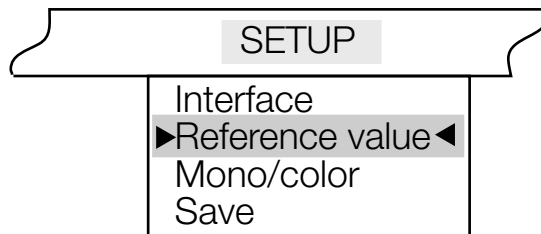

- |                        |  |
|------------------------|--|
| <b>Interface</b>       | Selection of the interface (Com 1 to Com 4) and adaptation to the interface parameter. Do not forget to save the new values after modifications.   |
| <b>Reference value</b> | Entering the reference value. Before ISODATA saves the measuring values, the deviation of the insulation fault RF from the previous measuring value is displayed in per cent. A value exceeding this percentage saves storage space on the storage medium. Pre-setting is 10%. |
| <b>Mono/color</b>      | Adaptation of ISODATA to colour resp. monochrome displays.   |
| <b>Save</b>            | Saving of modified settings into the file ISODATA.CFG.   |