

# POWERSCOUT®

Transparency for your electrical distribution systems



## POWERSCOUT®

Time = money and both are resources that are generally in short supply. Staff shortages, ever **stricter conditions and deadlines** and the constant need to optimise are the counterparts to this simple equation.

**Responsible electrically skilled persons** experience this more and more. They are specialists, but are perceived as all-rounders and are to a large extent responsible for the smooth functioning of operational processes. According to the motto "Just do this as well", **the actual tasks are increasingly being neglected.**

The **solution** is to **automate** routine and recurring mandatory tasks.

POWERSCOUT® helps you to achieve the following goals:

- Avoiding unwanted shutdowns
- Avoiding shutdowns as part of the periodic verification
- Fulfilling documentation obligation
- Visualising leakage and residual currents
- Minimising effort and costs
- Iso, RCMS and ATICS® report
- Automation of your reporting



# POWERSCOUT®



## POWERSCOUT® features

### Automated reports

Reports can be generated from the dashboards. A dashboard can always be sent and saved as a report. There is also an option for managing these reports. In the report management, the publishing intervals as well as the storage in POWERSCOUT® can be set.

- Automated report generation
- Freely configurable time periods
- Storing 250 reports in a history
- Sending reports via e-mail
- Insulation report, residual current report (German Social Accident Insurance Regulation 3 (DGUV V3)) and ATICS® report

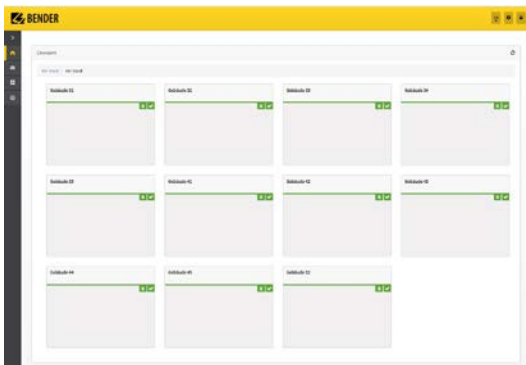
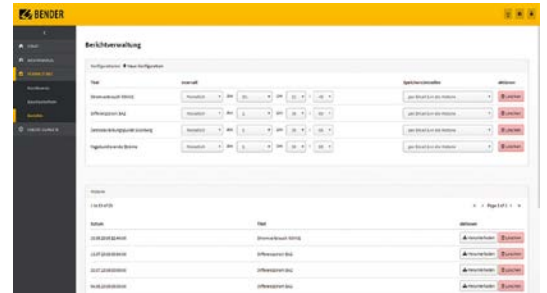

### Building and system overview

The installation/system can be displayed by means of freely configurable tiles. As soon as a warning or an alarm (residual current exceeded, insulation fault, upcoming test) occurs in one of the configured parts, it automatically appears on the screen.

- Individual design of buildings, floors and rooms or entire plants
- Navigation to the fault source
- Link to detailed view (dashboard) is possible
- Number of events of the last 28 days can be displayed
- Events and incidents in the system can be counted
- Identification of problematic system parts

### Individual appearance

- Logo freely selectable
- Colour setting to match your corporate design (CD)
- Login page can be integrated in your homepage

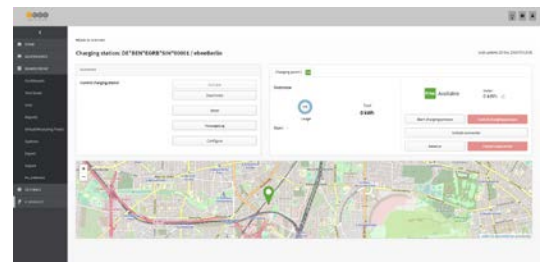

### Configurable dashboards

Dashboards can be used to visualise stored measured values and events. The contents can be structured using configurable widgets.

Among other things, time periods and different statistical values can be set. The dashboard can be easily and individually configured using drag and drop.

Additional settings are available in the dashboard management, e.g. publishing for other users.

- Configurable dashboards
  - Display of:
    - Charging current
    - Residual currents (DC/RMS)
    - Utilisation
    - ...
  - Comprehensive view by means of configurable widgets
  - Sharing dashboards with other users
  - Regular generation of PDF files + forwarding by e-mail
  - Long-term archiving of the data

# POWERSCOUT® features

### User management

- Management of users
- Different user rights
- Restricted views

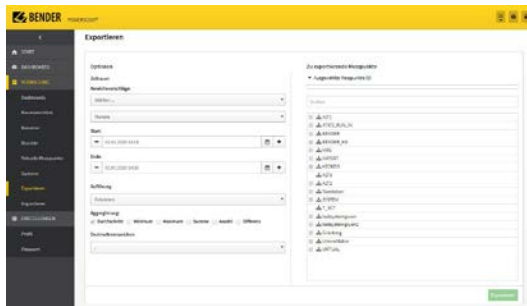
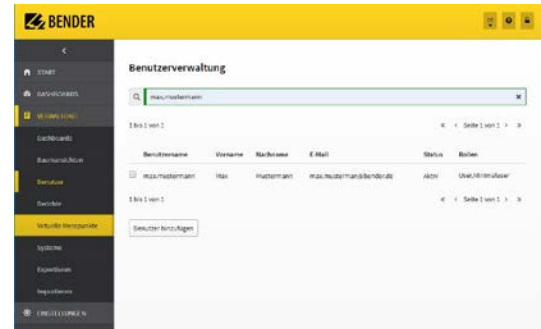

### Data import and export

### Data access from anywhere

Web-based application

- You can get started immediately after receiving the login details. Your gateway (COM465, CP9xx) sends the measured values to our data centre in encrypted form.
- You will receive automatic updates (security and features).
- We take care of the backups.

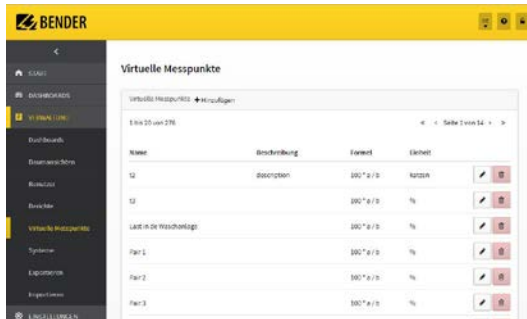
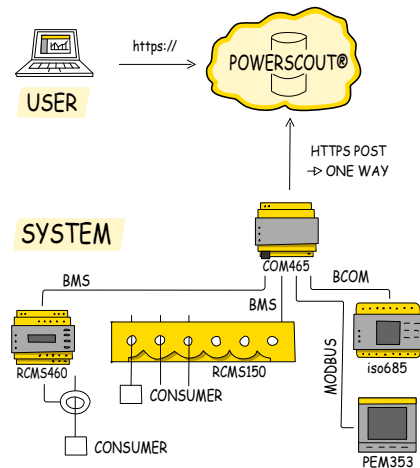

### Calculation of key figures

POWERSCOUT® collects data and information across locations. This data can be compiled for fault analysis or calculation of key figures.

- Calculation of data points/measuring points
- Display of virtual measuring points on the dashboard
- Individual naming of virtual measuring points

### Bender support

POWERSCOUT® continuously collects measurements and generates user-specific reports. This well-founded database allows representing real trend curves and finding the causes of malfunctions.

Bender supports you in setting up your system. Please do not hesitate to contact us.



# POWERSCOUT® widgets – Configuration options

Widgets are graphical components that allow individual adjustment of the content displayed in POWERSCOUT®. The widgets can be displayed in individual sizes and positions on a dashboard.

A dashboard can show a time period. The widgets displayed on the dashboard can differ from the set dashboard time and show individual time periods.

## Graph

- Linear and logarithmic representation
  - Insulation values can be displayed more clearly
- Scrolling and zooming with the mouse wheel is possible
- Display of events
- Minimum and maximum of the Y axis adjustable
- Two Y axes
- Line colour selection
- Adjustable line width
- Guides can be displayed

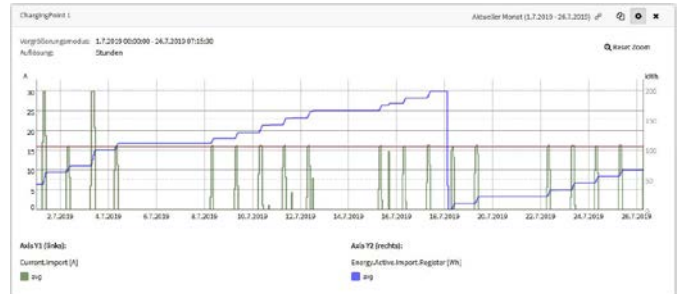

Anzahl der Ereignisse	Ereignis	Messpunktname	Type	Status	System	Subsystem	Gerät
2	Differenzstrom	FA03 1702-Hilgang 1/2	Verwarnung	Beginn	Gründung	0	10000 2 FA03 1702 47 1 1 0 0 00 00 00 00 00 00
2	Differenzstrom	FA03 1702-Hilgang 1/2	Verwarnung	Ende	Gründung	0	10000 2 FA03 1702 47 1 1 0 0 00 00 00 00 00 00
1	Differenzstrom	FA03 1702-Hilgang 1/3	Verwarnung	Beginn	Gründung	0	10000 2 FA03 1702 47 1 1 0 0 00 00 00 00 00 00
1	Differenzstrom	FA03 1702-Hilgang 1/3	Verwarnung	Ende	Gründung	0	10000 2 FA03 1702 47 1 1 0 0 00 00 00 00 00 00

## Event statistics

- Documentation of events
- State display of channels
- Start and end of events
- Tabular view
- Targeted search for events

## Event log

- Documentation of events
- State display of channels
- Start and end of events
- Tabular view
- Targeted search for events

Datum	Ereignis	Type	Status	Messwert	Messpunktname
30.12.2019 04:50:13	Differenzstrom	Warnung	Beginn	140 mA	F03_020107-04002_3-Messbar-104-Netzanschluss
30.12.2019 04:50:13	Differenzstrom	Warnung	Beginn	180 mA	F03_020107-04003_3-Messbar-1113-Unterflurkabelung 3-3/F-1113
30.12.2019 04:50:26	Differenzstrom	Warnung	Ende	---	F03_020107-04002_3-Messbar-104-Netzanschluss
30.12.2019 04:50:26	Differenzstrom	Warnung	Ende	---	F03_020107-04003_3-Messbar-1113-Unterflurkabelung 3-3/F-1113
30.12.2019 04:50:42	Differenzstrom	Warnung	Beginn	100 mA	F03_020107-04002_3-Messbar-104-Netzanschluss
30.12.2019 04:50:51	Differenzstrom	Warnung	Ende	---	F03_020107-04002_3-Messbar-104-Netzanschluss
30.12.2019 04:50:59	Differenzstrom	Warnung	Beginn	140 mA	F03_020107-04003_3-Messbar-104-Netzanschluss
30.12.2019 04:50:59	Differenzstrom	Warnung	Beginn	120 mA	F03_020107-04002_3-Messbar-1113-Unterflurkabelung 3-3/F-1113
30.12.2019 04:56:05	Differenzstrom	Warnung	Ende	---	F03_020107-04003_3-Messbar-104-Netzanschluss
30.12.2019 04:56:05	Differenzstrom	Warnung	Ende	---	F03_020107-04002_3-Messbar-1113-Unterflurkabelung 3-3/F-1113

Messpunktname	Beschreibung	Status
ZS.31.11.001_UNV002_ATICs_Ausfall Leitung 1 ZS	Ereignisse	✓
ZS.31.11.001_UNV002_ATICs_Ausfall Leitung 2 S1	Ausfall Leitung SV	!
ZS.31.11.001_UNV002_ATICs_Isolationsfehler	Ereignisse	✓
ZS.31.11.001_UNV002_ATICs_Trafo-Überlast	Ereignisse	✓
ZS.31.11.001_UNV002_ATICs_Trafo-Übertemperatur	Ereignisse	✓
ZS.31.11.001_UNV002_ATICs_Überstrom	Ereignisse	✓
ZS.31.11.001_UNV002_ATICs_Test/Service	Ereignisse	✓
ZS.31.11.001_UNV002_ATICs_Umschaltanlage im Handbetrieb	Automatikbetrieb	✓
ZS.31.11.001_UNV002_ATICs_Alarm	Automatikbetrieb	✓

## Alarm state

- Display of alarm states
- Fault detection at a glance
- Monitoring of the service state of your system
- Easy detection of residual currents across system parts

# POWERSCOUT® widgets – Configuration options

## Gauge

- Lower and upper limit values flexibly adjustable
- Monitoring of measured values

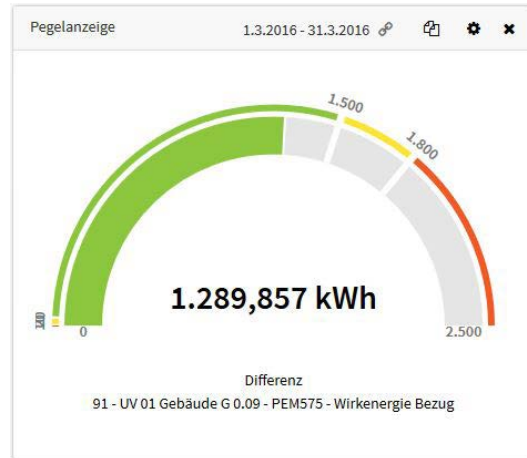

## Bar graph

- Display of cumulative meter values in a bar graph
- Grouping of data in ascending order
- Aggregation by days, weeks, months, quarters and years
- Guides can be displayed

## Table view

- Display of measured values in a table
- Minimum, maximum and average values can be displayed
- Complete overview of minimum, maximum and average values of several measured values

Messpunktname	Durchschnitt	Minimum	Maximum
Grünberg-1-126-Frequenz	50 Hz	0 Hz	50,107 Hz
Grünberg-1-126-I(1)	36,899 A	81,438 mA	199,807 A
Grünberg-1-126-I(2)	59,96 A	98,143 mA	335,544 A
Grünberg-1-126-I(3)	59,086 A	0 A	314,869 A
Grünberg-1-126-I(N)	66,668 mA	28,766 mA	164,241 mA
Grünberg-1-126-P (1)	8,158 kW	-6,792 kW	43,502 kW
Grünberg-1-126-P (2)	11,232 kW	-14,956 kW	72,787 kW
Grünberg-1-126-P (3)	11,627 kW	-14,065 kW	68,871 kW
Grünberg-1-126-U(1-N)	228,419 V	220,636 V	234,952 V
Grünberg-1-126-U(2-N)	228,665 V	220,833 V	236,297 V
Grünberg-1-126-U(3-N)	228,685 V	221,342 V	236,053 V

# POWERSCOUT® widgets – Configuration options

## Text editor

- Description of dashboards
- Adding custom images

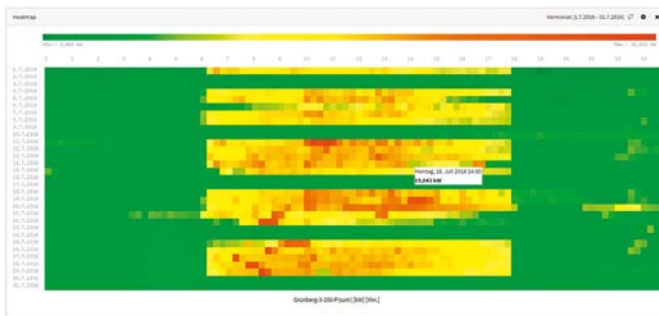
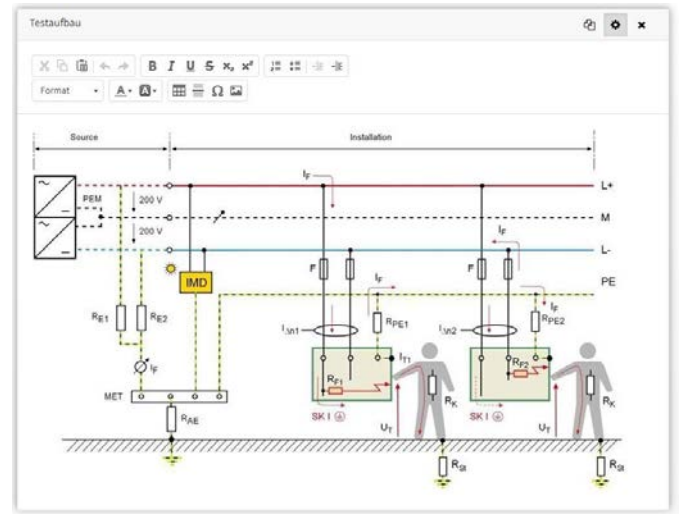

## Heat map

- Display particularly striking values in an easily recognisable way
- Colour inversion to allow insulation faults to be displayed as well
- Adjustable limit values

## Sankey diagram

- Graphic representation of quantity flows
- Preferably used for energy monitoring
- System view freely configurable

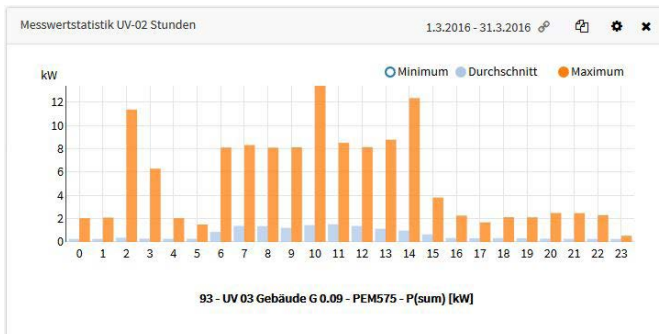
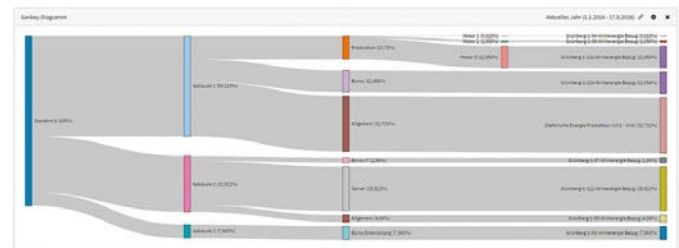

## Measurement statistics

- Display of a measured value as statistics
- Minimum, maximum and average values can be displayed
- Colour differentiation individually adjustable
- Guides can be displayed

# The Bender world in a nutshell

## Bender system world

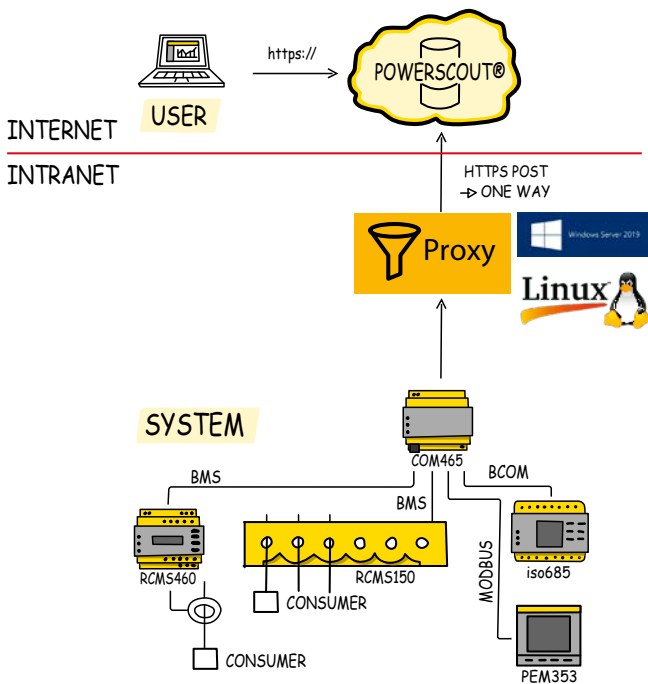
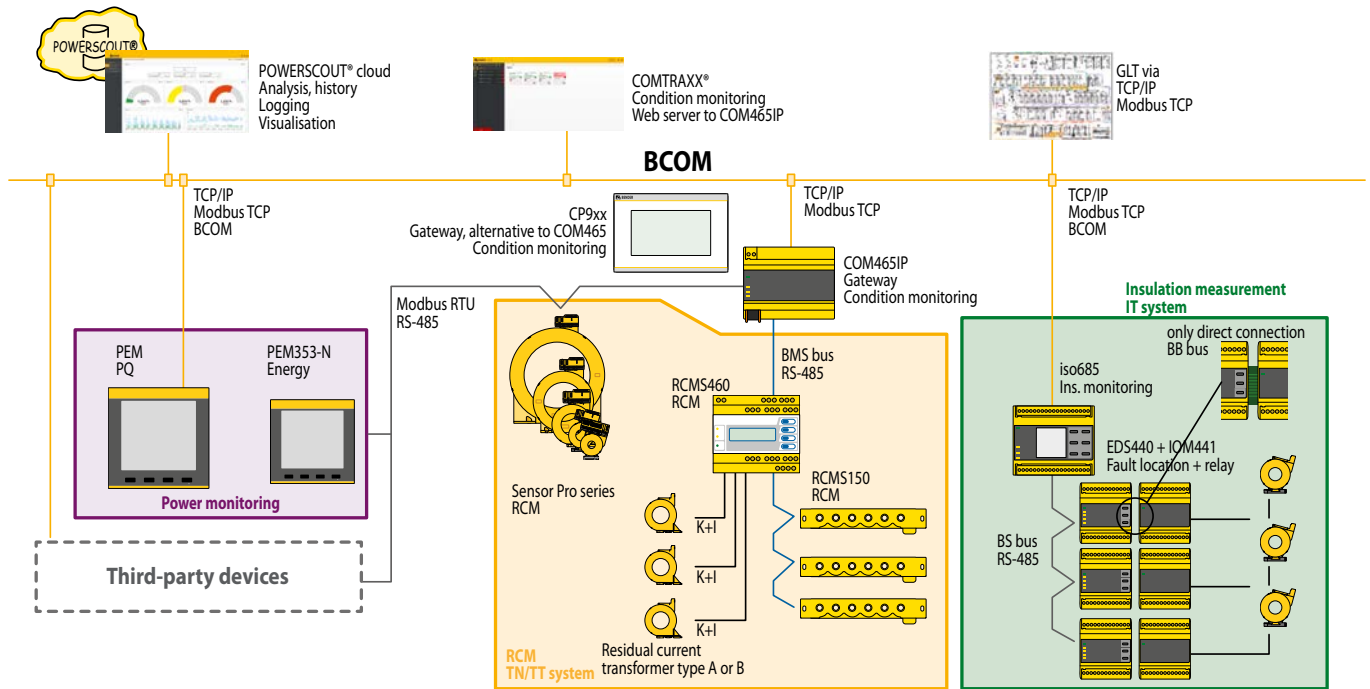

### Considerably less effort:

- The initial and ongoing project costs caused by in-house IT infrastructure are often overlooked
- No updates at the customer's site or by the customer
- No maintenance by the customer necessary
- No database maintenance by the customer necessary
- Hardware costs, memory expansions are not relevant
- Updates and new features are incorporated on the fly
- Access from any location without VPN etc.
- One-way data flow
- On request, communication via proxy server (simple installation)
- Data protection in professional data centres is better than in some companies
- Data backup constantly guaranteed, redundancy
- Hosted by a German company, server in Frankfurt



### Bender GmbH & Co. KG

Londorfer Straße 65 • 35305 Grünberg • Germany  
Tel.: +49 6401 807-0 • info@bender.de • www.bender.de



BENDER Group