



## CHARGING ELECTRIC VEHICLES PROTECTION AGAINST ELECTRIC SHOCK BY DC FAULT CURRENT SENSOR UNITS

In electromobility subjects a mutual exchange of information and the necessary knowledge transfer between power suppliers and vehicle developers are essential and the results are implemented into the standards. Protection against electric shock, for example, is particularly important in charging electric vehicles. Since decades, the Bender company are experts in the field of 'electrical safety'. This article facilitates a closer look at the specific electrical safety aspects when charging an electric vehicle.

## AUTHORS



**DIPL.-ING. WOLFGANG HOFHEINZ**  
is Managing Director Technology,  
CTO, at Bender GmbH & Co.KG in  
Gruenberg (Germany).



**DIPL.-ING. HARALD SELLNER**  
is Head of Technical Marketing at  
Bender GmbH & Co.KG in  
Gruenberg (Germany).



**DIPL.-ING. WINFRIED MÖLL**  
is Head of Division T-MIS at Bender  
GmbH & Co.KG in Gruenberg  
(Germany).

## BRIEF TECHNICAL SUBJECT MATTER

The DKE German Commission for Electrical Electronic and information technology in DIN and VDE, the national authority for developing standards and safety regulations, together with the Standard Committee Automotive (NA Automobile) are responsible for developing standards for the protection against electric shock in Germany. The e-mobility roadmap defines targets and sets benchmarks [1].

But, the devil is indeed often in the details. The possible coupling of direct and alternate voltage systems in the charging process is a real challenge. This article offers the reader a closer look to the specific charging systems of electric vehicles with regards to its electrical safety [2]. Different charging modes for charging battery powered electric vehicles (BEV) are defined in DIN EN 61851-1 (VDE 0122-1):2012 01 [3]. For AC charging at an electric socket-outlet or an AC charging station charging mode 2 and mode 3 might be considered. ❶.

According to the general requirements of DIN VDE 0100-410 (VDE 0100-410):2007-06 [4] subclause 411.3.3.3, a residual current protective device (RCD) shall be installed in final external circuits, in socket-outlets with a rated current  $\leq 20$  A and in final circuit  $\leq 32$  A for portable external equipment. This requirement is specified in the standard draft E DIN VDE 0100-722 (VDE 0100-722):2011-09 [5] inasmuch that each point of connection has to be protected with a residual current protective device (RCD), at least of type A. If the characteristics of the load in regards to possible fault currents  $I_f \geq 6$  mA are not identified, appropriate protective measures have to be taken in case of DC fault current. A combination of RCD type A and RCD type B in the same circuit is not permissible and must be adhered to in new installations.

## NORMATIVE REQUIREMENTS OF RESIDUAL CURRENT PROTECTIVE DEVICES (RCD) TYP A

According to IEC 61008-1 [6] and IEC 61009-1 [7], residual current protective devices (RCD) type A shall be provided for the following fault currents  $I_f$ :

- : sinusoidal alternating currents
- : pulsating DC fault currents.

Smooth DC fault currents up to a threshold of  $I_f = DC \leq 6$  mA are allowed to occur, ❷. In case of DC fault current  $I_f \geq 6$  mA, that may arise from an existing insulation fault within the on-board charger inside the vehicle, the response value as well as the response time may alter negatively in the upstream residual current protective device (RCD). In the worst case an RCD type A is not triggered or becomes “blind”. In this case, the protective function is no longer guaranteed. To prevent this, either a residual current protective devices (RCD) type B can be used or the potential DC fault current might be detected by other means to disconnect the circuit.

## SOURCE OF DC FAULT CURRENTS

In charging stations of battery-operated electric vehicles, PFC devices (Power Factor Correction) are used in order to meet the EMC requirements. ❸ shows an example for such a charging station.

In case of an isolation fault  $RF_1$  occurring on the input side of the PFC control (Power Factor Correction device), a DC fault current may arise. If this DC fault current exceeds the normative specified limit of  $I_f \geq 6$  mA, ❹, the residual current protective device (RCD) type A of the electric installation may adversely affect the response characteristic which means that the required protective function may not function as expected.

The current DIN VDE 0100-530 (VDE 0100-530):2011-06 [8] does not consider this type of fault current scenario and creates a new fault type in modern AC systems with modern drives and power supplies with PFC. Only the PE-N-connection in the installation closes the DC fault circuit and influences “all” RCDs type A in the circuit, ❺.

## FAULT CURRENT SENSOR UNITS

According to the requirements of DIN EN 61851-1 (VDE 0122-1):2012-01, the charging system under failure and single fault conditions must limit the flow DC mA and non-sinusoidal currents that could influence the proper function of the residual current protective device (RCD) or other devices.

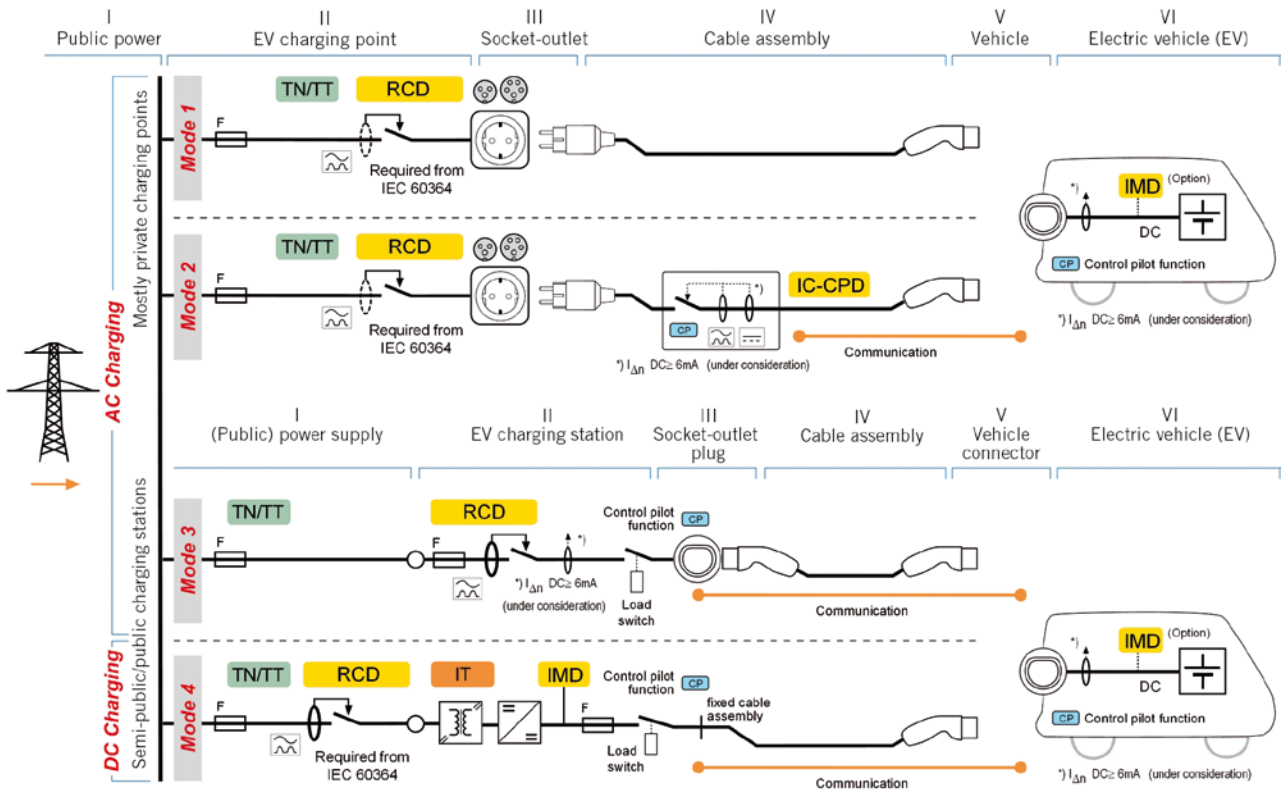

1 Overview – charging modes and protective measures

The standard draft E DIN VDE 0100-722 (VDE 0100-722):2011-09 contains similar requirements in 711.531.2.101: “If direct fault  $I_f \geq 6$  DC mA current occur, appropriate measures have to be taken.”

Another measure may be the detection of these direct fault currents with fault current sensor units with a control of the disconnection function, e.g.:

- : control of the charging socket in a charging station (mode 3)
- : control of the relay in an IC-CPD
- : control of the contacts in the electronics of the vehicle.

One of these measures ensures that the function of an (existing) RCD type A in the building installation is not adversely affected.

**SUMMARY**

The reliable protection against electric shock is one of the prerequisites for a successful approach to e-mobility. Comprehensive standardisation activities are being developed in the various committees of the DKE and of the DIN. The sensor unit described here is offering a way of increas-

ing the protection level. The essential protection against electric shock through the residual current protective device (RCD) type A continues to be ensured by the DC 6 mA-sensor unit and the characteristics of the fault current device are kept. The two

different system types in the infrastructure and the car, and their protective measures require special attention during charging. The solutions by the experts from the aforementioned fields of expertise are integrated into the standards.

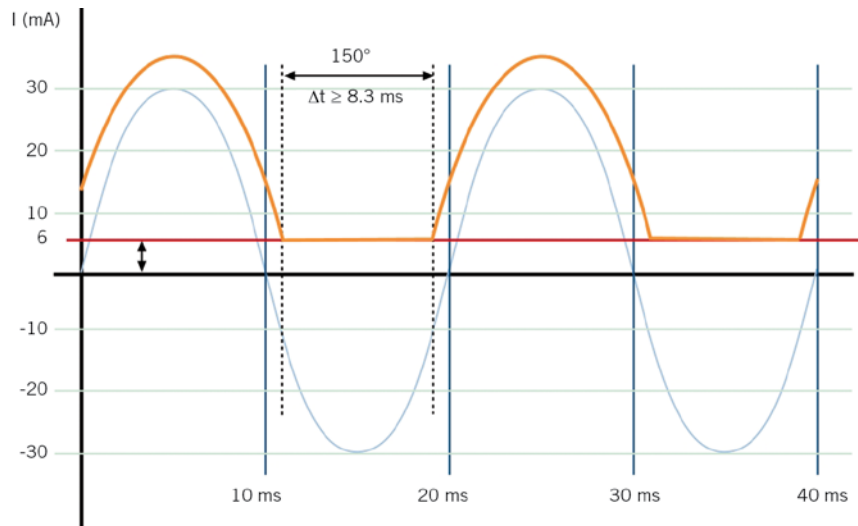

2 Definition fault current  $I_f \geq 6$  DC mA according to IEC/TR 60755

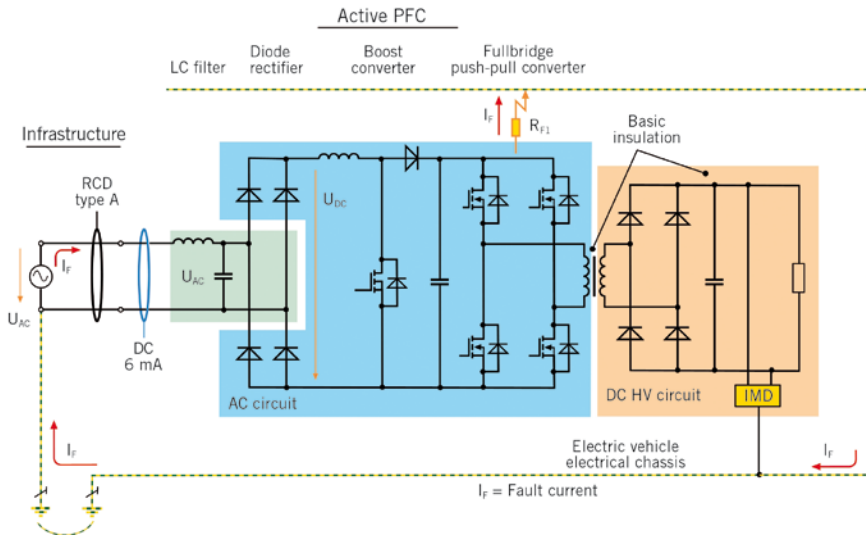

3 Example structure of an on-board charger

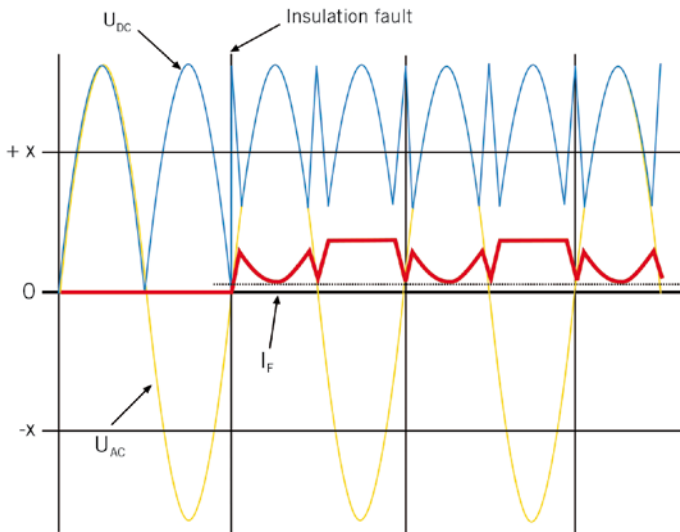

4 Modelled dc fault current  $I_F$  with insulation fault  $R_{F1}$

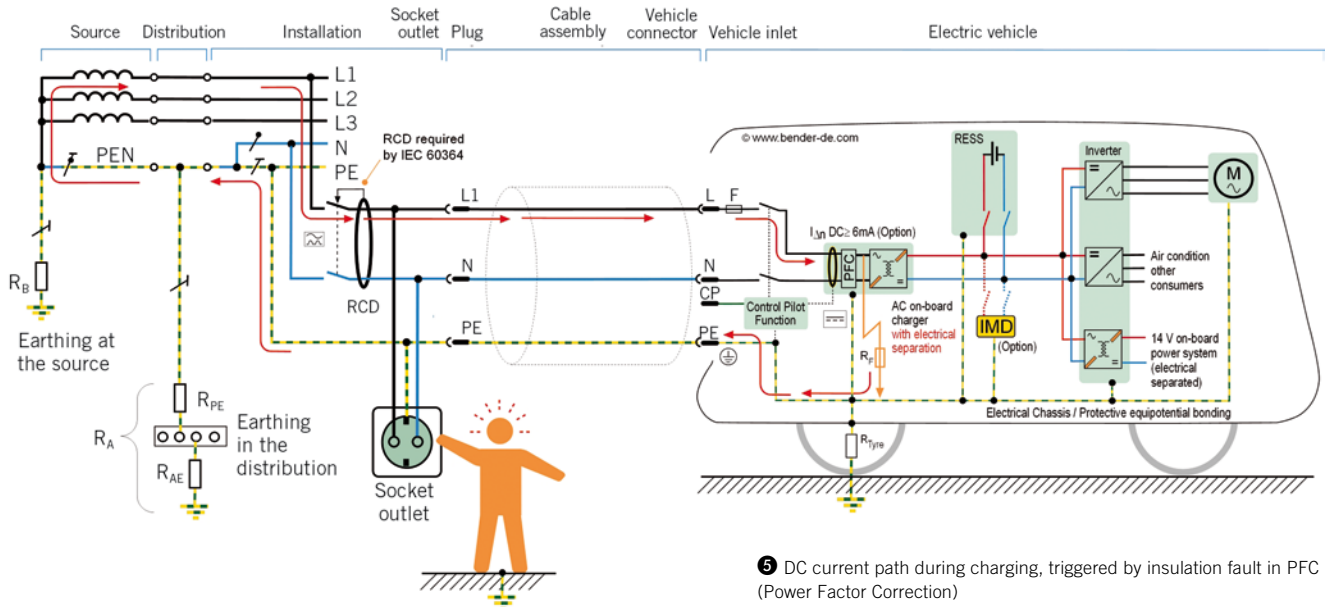

5 DC current path during charging, triggered by insulation fault in PFC (Power Factor Correction)

REFERENCES

- [1] Die deutsche Normungs-Roadmap, Elektromobilität – Version 2, January 2012, DKE, www.dke.de
- [2] Hofheinz, W.: VDE-Schriftenreihe Band 114, 3. Auflage: Schutztechnik mit Isolationsüberwachung, 2011, VDE-Verlag Berlin/Offenbach
- [3] DIN EN 61851-1 (VDE 0122-1):2012-01: Elektrische Ausrüstung von Elektro-Straßenfahrzeugen – Konductive Ladesysteme für Elektrofahrzeuge Teil 1: Allgemeine Anforderungen
- [4] DIN VDE 0100-410 (VDE 0100-410):2007-06: Errichten von Niederspannungsanlagen, Teil 4-41: Schutzmaßnahmen – Schutz gegen elektrischen Schlag
- [5] E DIN VDE 0100-722 (VDE 0100-722):2011-09, Errichten von Niederspannungsanlagen, Teil 7-722: Anforderungen für Betriebsstätten, Räume und Anlagen besonderer Art – Stromversorgung von Elektrofahrzeugen
- [6] IEC 61008-1 ed3.1 Consol. with am1 (2012-04): Residual current operated circuit-breakers without integral overcurrent protection for household and similar uses (RCCBs) – Part 1: General rules
- [7] IEC 61009-1 ed3.1 Consol. with am1 (2012-04): Residual current operated circuit-breakers with integral overcurrent protection for household and similar uses (RCBOs) – Part 1: General rules
- [8] DIN VDE 0100-530 VDE 0100-530:2011-06: Errichten von Niederspannungsanlagen, Teil 530: Auswahl und Errichtung elektrischer Betriebsmittel – Schalt- und Steuergeräte
- [9] IEC/TR 60755 ed2.0 (2008-01): General requirements for residual current operated protective devices